

DIGITAL METERS

Large Display Temperature Meters

Instruction Manual

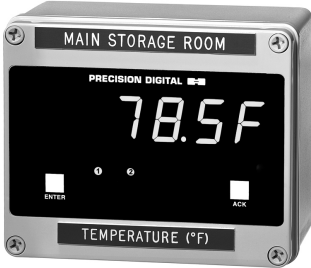

PD755



PD756



PD757

- Handles Thermocouple & RTD Inputs with Simplicity
- J, K, T, E, R, & S Thermocouples
- 100 Ω Platinum RTD (0.00385 or 0.00392 curve)
- Large Display Readouts: 2.3", 1.0" and 0.8" High
- Display Resolution

Thermocouple: 1°, Type T T/C Displayed to 1° or 0.1°

RTD Resolution: 1° or 0.1°, Field Selectable

- Displays °F or °C, Field Selectable
- No Calibration Necessary – Factory Calibrated
- Maximum/Minimum Temperature Display
- Input Offset Adjustment
- NEMA 4X and Explosion-Proof Enclosures
- 115 or 230 VAC Power, Field Selectable
- 24 VDC Powered Models, Optional
- 24 VDC Isolated Power Supply Standard on AC Models
- 4 Visual Alarm Points with Front Panel LED Status Indication
- 2 or 4 Relays and/or 4-20 mA Output Options

PRECISION DIGITAL CORPORATION

19 Strathmore Road • Natick MA 01760 USA

Tel (800) 343-1001 • Fax (508) 655-8990



www.predig.com

Visit our Website
<http://www.predig.com>

Table of Contents

INTRODUCTION -----	7
Ordering Information -----	7
Model PD755 NEMA 4X Polycarbonate Enclosure -----	7
Model PD756 Explosion-Proof Enclosure -----	7
Model PD757 NEMA 4X Aluminum Enclosure -----	8
Accessories -----	8
Safety Notice -----	9
Specifications -----	10
Basic Temperature Meter -----	10
Options -----	12
Display Functions and Messages -----	14
SETUP AND PROGRAMMING -----	15
Overview -----	15
Disassembling the Meter -----	16
Disassembling the PD755 -----	16
Disassembling the PD756 -----	16
Disassembling the PD757 -----	17
Reassembling the Meter -----	18
Reassembling the PD755 -----	18
Reassembling the PD756 -----	18
Reassembling the PD757 -----	18
Jumper Configuration -----	19
Input Selection and Lockout Jumpers (Main Board) -----	19
Relay Acknowledge Enable (Display Board)-----	19
Fail-Safe Operation of Relays (Options Board) -----	19
Power Selection -----	20
Overview -----	20
Changing from 115 to 230 VAC Power -----	20
Labeling Meter for 115 VAC, 230 VAC or 24 VDC -----	21
Connections -----	21
Overview -----	21
Wiring Instructions -----	22
Terminals Designation -----	22
Power Connections -----	23
Signal Connections-----	24
Enter, Acknowledgement, and Hold Connections -----	26
Optional Relays & 4-20 mA Output Terminals -----	27
Isolated 4-20 mA Output Transmitter Connections -----	28
Programming -----	29
Overview -----	29
Select Type of Input Signal T/C or RTD-----	29
ENTER Button Functionality -----	30
ACK Button Functionality -----	30
Magnetic Reed Switch Functionality -----	30
General Programming Description -----	31
Five Basic Digit/Display-Setting Instructions -----	31

Programming the Basic Meter-----	32
Selecting Type of T/C or RTD (TYPE)-----	33
Select °F or °C (F or C)-----	33
Alarm Setup and Set Points Programming-----	34
Overview-----	34
Set Relays for Manual or Automatic Reset-----	34
Set Relays for Fail-Safe Operation-----	34
Setup for Latching or Non-Latching Relays (SETUP)-----	35
Alarm Set and Reset Points Programming-----	36
Programming Alarm Points Using Set Points (SETPOINT5) Menu-----	37
Alarm Set and Reset Programming Confirmation-----	37
Isolated 4-20 mA Output Transmitter Option-----	38
4-20 mA Output Programming (OUTPUT)-----	38
4-20 mA Output Programming Confirmation-----	38
Input Offset Adjustment (OFFSET)-----	39
Lockout Jumper-----	39
OPERATION-----	40
Overview-----	40
Basic Meter Operation-----	41
Overview-----	41
Maximum/Minimum Temperature Display-----	41
Relays Operation-----	42
Overview-----	42
Relays Auto Initialization-----	42
Fail-Safe Operation-----	42
Front Panel LEDs-----	43
Acknowledging Relays-----	45
Switching Inductive Loads-----	46
4-20 mA Output Operation-----	46
RECALIBRATION (CALIB)-----	47
Calibration Error (ERROR)-----	47
Recommended Calibration Points-----	48
Minimum Input Span-----	48
Calibration Verification-----	48
INSTALLATION-----	49
Wall Mounting Instructions-----	49
PD755 Mounting-----	49
PD756 Mounting-----	49
PD757 Mounting-----	49
Panel Mounting Instructions-----	50
PD755 Panel Mounting Instructions-----	50
PD757 Panel Mounting Instructions-----	51
Pipe Mounting Instructions for PD755 and PD756-----	53
Explosion-Proof Control Stations-----	55
OPTION CARD REMOVAL & INSTALLATION-----	56
Option Card Installation in PD755-----	56
Option Card Installation in PD756-----	58
Option Card Installation in PD757-----	59

MODEL SPECIFIC ILLUSTRATIONS -----	60
Removing the Display Board -----	60
Locations of Connections and Jumpers -----	61
Jumper Arrays and Status LEDs -----	63
Front Panel Displays -----	65
Overall Dimensions -----	66
Wall Mounting Dimensions -----	67
PROGRAMMED PARAMETER SETTINGS -----	69
OTHER PRECISION DIGITAL PRODUCTS -----	70

List of Figures

Figure 1.	Input Power Label	21
Figure 2.	Input Power Connections for 756 and 757	23
Figure 3.	Four-Wire RTD Connections	24
Figure 4.	Three-Wire RTD Connections.....	24
Figure 5.	Two-Wire RTD Connections	25
Figure 6.	Thermocouple Connections.....	25
Figure 7.	External Control Connections.....	26
Figure 8.	Relay and 4-20 mA Output Terminals.....	27
Figure 9.	Output Loop Powered by Meter	28
Figure 10.	Output Loop Powered from External Power Supply	28
Figure 11.	JP1 Input Signal Selection Array.	29
Figure 12.	Reed Switch Operation	30
Figure 13.	AC and DC Loads Protection	46
Figure 14.	Low Voltage DC Loads Protection.....	46
Figure 15.	PD755 Panel Mounting.....	50
Figure 16.	PD757 Panel Mounting.....	51
Figure 17.	PD757 Panel Mounting Cutout Dimensions	51
Figure 18.	755 Pipe Mounting Assembly	53
Figure 19.	756 Pipe Mounting Assembly	53
Figure 20.	Pipe Mounting Plate	54
Figure 21.	Explosion-proof Control Station	55
Figure 22.	Removing the PD755 Display Board.....	56
Figure 23.	PD755 Options Board Standoffs Location	56
Figure 24.	PD755 Options Board Installation.....	57
Figure 25.	PD756 Option Board Installation.....	58
Figure 26.	PD756 Option Board Installed	58
Figure 27.	PD757 Option Board Installation.....	59
Figure 28.	Removing the Display Board on PD755	60
Figure 29.	Removing the Display Board on PD756	60
Figure 30.	Removing the Display Board on PD757	61
Figure 31.	PD755 Connectors and Jumper Location	61
Figure 32.	PD756 Connectors and Jumper Location	62
Figure 33.	PD757 Connectors and Jumper Location	62
Figure 34.	PD755 Jumper Arrays and Status LED Identification.....	63
Figure 35.	PD756 Jumper Arrays and Status LED Identification.....	63
Figure 36.	PD757 Jumper Arrays and Status LED Identification.....	64
Figure 37.	PD755 Front Panel Display	65
Figure 38.	PD756 Front Panel Display	65
Figure 39.	PD757 Front Panel Display	65
Figure 40.	PD755 Overall Dimensions	66
Figure 41.	PD756 Overall Dimensions	66
Figure 42.	PD757 Overall Dimensions	67
Figure 43.	PD755 Wall Mounting Dimensions.....	67
Figure 44.	PD755 Wall Mounting Screw Installation	67
Figure 45.	PD756 Wall Mounting Dimensions.....	68
Figure 46.	PD757 Wall Mounting Dimensions.....	68

INTRODUCTION

The Large Display Temperature Meters are housed in rugged, NEMA 4X or explosion-proof enclosures. These meters handle temperature display and alarm applications with simplicity, accuracy, and reliability. They accept the common thermocouples J, K, T, E, R, and S or 100 Ω platinum RTD. Options include up to 4 relays for alarms as well as an isolated 4-20 mA transmitter output. An isolated 24 VDC power supply is available as standard feature on AC powered models to power the transmitter output.

Ordering Information

Model PD755 NEMA 4X Polycarbonate Enclosure

115/230 VAC MODEL	24 VDC MODEL	Options Installed	Option Card*
PD755-N	PD755-2-N	No Options	
PD755-44	PD755-2-44	2 Relays	PD474
PD755-45	PD755-2-45	4-20 mA Output	PD475
PD755-46	PD755-2-46	2 Relays + 4-20 mA Output	PD476
PD755-47	PD755-2-47	4 Relays	PD477
PD755-48	PD755-2-48	4 Relays + 4-20 mA Output	PD478

Model PD756 Explosion-Proof Enclosure

115/230 VAC MODEL	24 VDC MODEL	Options Installed	Option Card*
PD756-N	PD756-2-N	No Options	
PD756-44	PD756-2-44	2 Relays	PD474
PD756-45	PD756-2-45	4-20 mA Output	PD475
PD756-46	PD756-2-46	2 Relays + 4-20 mA Output	PD476
PD756-47	PD756-2-47	4 Relays	PD477
PD756-48	PD756-2-48	4 Relays + 4-20 mA Output	PD478

*Option Cards (When Ordered Separately)

Model PD757 NEMA 4X Aluminum Enclosure

115/230 VAC MODEL	24 VDC MODEL	DESCRIPTION	Option Card*
PD757-N	PD757-2-N	No Options	
PD757-34	PD757-2-34	2 Relays	PD374
PD757-35	PD757-2-35	4-20 mA Output	PD375
PD757-36	PD757-2-36	2 Relays + 4-20 mA Output	PD376
PD757-37	PD757-2-37	4 Relays	PD377
PD757-38	PD757-2-38	4 Relays + 4-20 mA Output	PD378

Option Cards (When Ordered Separately)*Accessories**

Control Stations		
Model	Switches	Labels
PDA2451-E	1	ENTER
PDA2451-A	1	ACK
PDA2451-R	1	RESET
PDA2452-EA	2	ENTER and ACK
PDA2452-ER	2	ENTER and RESET
PDA2453-EAR	3	ENTER, ACK, and RESET

PDA-MAG	Magnet Assembly for PD656 & PD756
PDA6504	Panel Mounting Kit for PD757**
PDA6554	Panel Mounting Kit for PD755**
PDA6545	2" Pipe Mounting Kit for PD755 and PD756
PDA6545-SS	2" Pipe Mounting Kit for PD755 and PD756 SS

** These panel mounting kits are not intended to provide waterproof protection to the panel.

Safety Notice

CAUTION: Read complete instructions prior to installation and operation of the meter.



WARNING: Risk of electric shock.



Observe all safety regulations. Electrical wiring should be performed in accordance with all applicable national, state, and local codes to prevent damage to the meter and ensure personnel safety.



It is recommended to use this meter in a fail-safe system that accommodates the possibility of meter failure or power failure.

**WARNING**

Hazardous voltages exist within enclosure. Installation and service should be performed only by trained service personnel.

**AVERTISSEMENT**

Les pièces à l'intérieur du boîtier portent des tensions dangereuses. Seules des personnes qualifiées et bien entraînées devraient entreprendre l'ótalonnage et la maintenance.

Disclaimer

The information contained in this document is subject to change without notice. Precision Digital makes no representations or warranties with respect to the contents hereof, and specifically disclaims any implied warranties of merchantability or fitness for a particular purpose.

Specifications

Except where noted all specifications apply to operation at +25°C.

Basic Temperature Meter

INPUTS	Field selectable: type J, K, T, E, R, or S thermocouples with 1° resolution; type T to 0.1°; 100 Ω platinum RTD (0.00385 or 0.00392 curve) to 1° or 0.1° resolution.		
DISPLAY	4½ digit red LED, automatic lead zero blanking, F or C displayed to indicate Fahrenheit or Celsius. Digit Size: PD755– 1.0" (25.4 mm) high PD756– 0.8" (20.3 mm) high PD757– 2.3" (58.0 mm) high		
COLD JUNCTION REFERENCE	Automatic, fixed, no user calibration needed.		
INPUT IMPEDANCE	Greater than 100 kΩ		
LOCKOUT	Jumper JP2, located on Main Board, restricts modification of set values.		
ACCURACY	Input Type	Range	Accuracy
	Type J T/C	–328° to 1382° F –200° to 750°C	±2°F ±1°C
	Type K T/C	–328° to 2498°F –200° to 1330°C	±2°F ±1°C
	Type T T/C	–330.0° to 760.0°F –200.0° to 404.0°C	±2°F ±1°C
	Type E T/C	–328° to 1832°F –200° to 1000°C	±2°F ±1°C
	Type R T/C	32° to 3213°F 0° to 1767°C	±5°F ±3°C
	Type S T/C	40° to 3214°F 4° to 1768°C	±6°F ±3°C
	100 Ω RTD	–328.0° to 1382.0°F –200.0° to 750.0°C	±0.7°F ±0.4°C
RECALIBRATION	All ranges are calibrated at the factory. Recalibration is recommended at least every 12 months.		
INPUT OFFSET	Programmable to ±100% FS display. This parameter allows the user to apply an offset value to the input temperature being displayed.		
SENSOR BREAK DETECTION	Open sensor circuit indicated by display flashing DPEn . All relays and alarm status LEDs go to alarm state.		
MAX/MIN TEMPERATURE DISPLAY	The maximum and minimum temperature reached by the process is stored in memory until cleared (reset) by the user or until power to the meter is turned off. Max/min values are displayed via the ENTER button and H I E, L O E menu functions, respectively.		

ALARM POINTS	Four, any combination of high or low alarms. Latching or non-latching.
ALARM POINT DEADBAND	0-100% of full scale, user selectable
ALARM STATUS INDICATION	Front panel LED
NON-VOLATILE MEMORY	All programming values are stored in non-volatile memory for a minimum of ten years if power is lost.
NORMAL MODE REJECTION	64 dB at 50/60 Hz
POWER OPTIONS	AC power: 115 or 230 VAC (field select) $\pm 10\%$, 50/60 Hz, 12 VA DC power: 22-28 VDC; 12 watts maximum
ENVIRONMENTAL	Operating temperature range: 0 to 65°C Storage temperature range: -40 to 85°C Relative humidity: 0 to 90% non-condensing
CONNECTIONS	Removable screw terminal blocks accept 22 to 12 AWG wire.
ENCLOSURE	
PD755	Impact-resistant glass-filled polycarbonate, NEMA 4X, IP67, color: gray (RAL 7035), two holes for ½" conduit provided at base.
PD756	Explosion-proof sand-cast aluminum with glass window, 0.3% max copper content, NEMA 4, 7, & 9, IP66. UL Classified & CSA Certified Class I Groups C & D, Class II Groups E, F & G, Class III hazardous outdoor (Type 4) locations. Two ¾" NPT holes provided at opposite sides. Up to four holes can be provided for an additional charge.
PD757	Die-cast aluminum, NEMA 4X, IP66/67, corrosion resistant, 0.1% max copper content, color: gray (RAL 7001) polyester powder paint. Four holes for ½" conduit provided at base, 3 plugs provided.
MOUNTING	
PD755	Enclosure contains four holes for wall mounting. Panel mounting and pipe mounting kits available.
PD756	Enclosure contains four 7/16" holes for wall mounting, pipe mounting kit available.
PD757	Enclosure contains four ¼" holes for wall mounting. Panel mounting kit available.
OVERALL DIMENSIONS	
PD755	6.7" x 5.5" x 3.7" (170 mm x 140 mm x 95 mm)
PD756	8.0" x 8.0" x 5.7" (203 mm x 203 mm x 145 mm)
PD757	4.9" x 14.3" x 3.2" (125 mm x 362 mm x 81 mm)
WEIGHT	
PD755	3.8 lbs (1.73 kg)
PD756	14.6 lbs (6.6 kg)
PD757	7.0 lbs (3.2 kg)
WARRANTY	2 years parts & labor
EXTENDED WARRANTY	1 or 2 years, refer to the Price List for details.

Options

Relays

RATING

2 or 4 SPDT (Form C); rated 2 A @ 30 VDC or 2 A @ 250 VAC resistive load; $\frac{1}{14}$ HP @ 125/250 VAC for inductive loads. Built-in suppression.

RESET

User select via JP5 jumper array and **5EtUP** menu.

Automatic reset only.

Manual reset only, at any time.

Automatic plus manual reset at any time.

Manual reset only after alarm condition has been corrected.

Automatic reset: Relays will automatically reset when the input passes the reset point.

Manual reset: It can be performed via user supplied external contact closure at terminals AK and CM or front panel ACK button.

Note: Manual reset resets all manually resettable relays.

BUILT-IN SUPPRESSION

A built-in suppressor (snubber) to prolong the life of the relays protects each relay contact. The suppressor provides a degree of protection against electrical noise caused by inductive loads. Suppressor value, 0.01 μ F/470 Ω , 250 VAC.

DEADBAND

0-100% of full scale, user selectable.

FAIL-SAFE OPERATION

Relay coils are energized in non-alarm condition. In case of power failure, relays will go to alarm state. Fail-safe operation may be disabled, by removing jumper J5 located on the Options Board.

SENSOR BREAK DETECTION

Open sensor circuit indicated by display flashing **OPEN**. All relays and alarm status LEDs go to alarm state.

AUTO INITIALIZATION

When power is applied to the meter, the relays always reflect the state of the input to the meter.

Isolated 4-20 mA Transmitter Output

CALIBRATION RANGE

The transmitter output can be calibrated so that a 4 mA output is produced for any number displayed on the meter. The 20 mA output may correspond to any number displayed on the meter (larger or smaller). However, best results are obtained with a 500-count difference between 4 and 20 mA displays. The output will be linear (example: 4 mA = 0°, 20 mA = 1000°, output is 6 mA at 125°.)

ACCURACY

$\pm 0.1\%$ FS $\pm .004$ mA @ 25°C

NO EQUIPMENT NEEDED

The 4-20 mA output from the Temperature Meter is calibrated via the **ENTER** button without the use of a calibrator.

OUTPUT LOOP-POWER

24 VDC $\pm 5\%$ @ 20 mA, regulated. Maximum loop resistance is 1200 Ω . Isolated from input signal.

ISOLATION

500 V input-to-output or input/output-to-24 VDC supply

EXTERNAL LOOP-POWER SUPPLY

35 VDC maximum

OUTPUT LOOP RESISTANCE

Power supply	Minimum loop resistance	Maximum loop resistance
24 VDC	10 Ω	600 Ω
35 VDC (external)	600 Ω	1000 Ω

Display Functions and Messages

The meter displays various functions and messages during operation and programming. The following table shows the various displayed functions and messages with their description.

Display	Parameter	Description/Comments
9999F	Out of range	Indicates the input signal exceeds the full-scale range of the meter.
CAL Ib	Calibration	Calibrates meter using a calibrated signal source.
CLEAR	Clear	Clears (resets) maximum or minimum temperatures reached by the process.
d I99	Diagnostic	Displays parameter settings one at a time for diagnostic purposes. Setting cannot be changed under this function.
Error	Error	Indicates calibration was not successful.
F or C	°F or °C	Type of scale to be used Fahrenheit or Celsius.
H I t	High temperature	Displays maximum temperature reached by the process since last cleared (reset).
INPt 1	Input 1	Sets low input calibration (low input signal must be applied to the meter).
INPt 2	Input 2	Sets high input calibration (high input signal must be applied to the meter).
LO t	Low temperature	Displays minimum temperature reached by the process since last cleared (reset).
LATCH	Latch	Sets alarm set points for latching or non-latching relay operation.
OFFSEt	Input offset	Adds or subtracts a programmed offset value to the input.
OPEN	Open	Indicates open sensor circuit.
outPut	Output	Sets the optional 4-20 mA output values.
SEt 1	Set point 1	Sets operation for Set point 1.
SEt 2	Set point 2	Sets operation for Set point 2.
SEt 3	Set point 3	Sets operation for Set point 3.
SEt 4	Set point 4	Sets operation for Set point 4.
SEtPtS	Set points	Sets alarm set and reset point values.
SEtUP	Setup	Sets operation of set points for latching or non-latching mode.
tYPE	Type	Sets type of thermocouple or RTD to be used as the input. Jumper JP1 must be configured accordingly.

SETUP AND PROGRAMMING

Overview

To setup and program the Digital Temperature Meter, it is necessary to disassemble the Display Board. See disassembling instructions in the next pages.

Setting up and programming the Digital Temperature Meter involves four basic steps:

1. Jumper Configuration (Page 19)
 - a. Input selection and lockout jumpers
 - b. Relay acknowledge enable
 - c. Fail-safe operation of relays
2. Power Selection (Page 20)
 - a. Changing to 230 VAC power if needed. 115 VAC is factory default on AC powered models.
 - b. Labeling meter for power input: 115 VAC or 230 VAC (24 VDC powered models are labeled as such at the factory).
3. Connections (Page 21)
 - a. Power connections
 - b. Signal connections
 - c. Enter, acknowledgement, and hold reading
 - d. Relays connections
 - e. 4-20 mA output connections
4. Programming (Page 29)
 - a. Basic meter
 - b. Alarm setup and set points
 - c. 4-20 mA output
 - d. Lockout jumper

Programmed Parameter Settings

To simplify programming, write down the desired programming values prior to attempting to program the meter. The ***Programmed Parameter Settings*** form, located on page 69, provides a convenient method to record the user settings; it also provides the factory setting for most of the programmable parameters.

Disassembling the Meter

To perform the steps described above, it is necessary to partially disassemble the meter. Main Board may remain attached to enclosure's base even during conduit hub installation if proper precautions are taken.

Disassembling the PD755

1. Loosen the four screws that hold enclosure's cover and remove the cover.
2. Remove the four mounting screws holding the Display Board (see Figure 28, page 60).
3. Move the Display Board out of the way. The ribbon cable to the Display Board may be removed during meter installation. **Do not remove standoffs from the Main Board.** The Main Board is secured to enclosure's base with four mounting screws.
4. Change voltage selection as required; this is described on page 20. Set configuration jumpers; connect power and signal wires.
5. Reassemble Display Board prior to applying power.
6. Program meter prior to installing enclosure's cover.
7. Install lockout jumper to prevent accidental changes to programmed settings.

Disassembling the PD756



When servicing the PD756 in a hazardous area, all appropriate hazardous area procedures must be followed.

1. Remove enclosure's cover.
2. Loosen the two mounting screws on the right side of the Display Board (see Figure 29 on page 60). It is not necessary to remove the faceplate.
3. Remove the two mounting screws on the left side of the Display Board.
4. Slide the Display Board out from under the screws. The ribbon cable to the Display Board may be removed during meter installation. **Do not remove standoffs from the Main Board.** The Main Board is secured to enclosure's base with four mounting screws.
5. Change voltage selection as required, described on page 20. Set configuration jumpers; connect power and signal wires.
6. Reassemble the Display Board prior to applying power.
7. To program meter using front panel buttons leave cover off until meter programming is complete.
8. Install lockout jumper to prevent accidental changes to programmed settings.

Disassembling the PD757

1. Loosen the four screws that hold the enclosure's cover in place and remove cover.
2. Loosen the top three mounting screws holding the Display Board (see Figure 30, page 61).
3. Remove the bottom three mounting screws.
4. Slide the Display Board out from under the top three screws. The ribbon cable to the Display Board may be removed during meter installation. **Do not remove standoffs from the Main Board.** The Main Board is secured to enclosure's base with four mounting standoffs.
5. Change voltage selection as required, described on page 20. Set configuration jumpers; connect power and signal wires.
6. Reassemble Display Board prior to applying power.
7. To program meter using front panel buttons leave top cover off until meter programming is complete.
8. Install lockout jumper to prevent accidental changes to programmed settings.

Reassembling the Meter

After the wiring and jumper selections have been made, reassemble the Display Board.

Reassembling the PD755

1. Place the Display Board on top of the four standoffs. Make sure the ribbon cable is connected to the connector on the Display Board.
2. Replace the four mounting screws (see Figure 28 on page 60).
3. Install enclosure's cover matching enclosure base and cover tabs.
4. Fasten the four screws that hold the enclosure cover in place.

Reassembling the PD756

1. Slide the Display Board under the two screws on the right side of the Display Board (see Figure 29 on page 60).
2. Replace the two mounting screws on the left side of the Display Board.
3. Tighten the two mounting screws on the right side of the Display Board
4. To program the meter using the front panel buttons leave cover off until meter programming is complete.
5. Replace the enclosure cover.

Reassembling the PD757

1. Slide the Display Board under the top three screws (see Figure 30, page 61).
2. Replace the bottom three mounting screws.
3. Tighten the top three mounting screws.
4. Align the enclosure cover so the alarm numbers on the cover are on the left side of the meter and aligned with the alarm status LEDs.
5. To program the meter using the front panel buttons leave top cover off until meter programming is complete.
6. Replace the enclosure cover and tighten the four screws that hold it in place.

Jumper Configuration

Before programming the Digital Temperature Meter, it is necessary to configure three jumper arrays. The jumper arrays are used for setting type of input signal (thermocouple or RTD), lockout programmed settings, enable relay acknowledgement (ACK), and setting relay fail-safe operation.

Input Selection and Lockout Jumpers (Main Board)

Figure 31 on page 61 for PD755

Figure 32 on page 62 for PD756

Figure 33 on page 62 for PD757

Jumper JP1 Position	Function
RTD	RTD Input
TC	Thermocouple Input
Jumper JP2 Position	Function
LOCK	Sets a lock on programming functions

Relay Acknowledge Enable (Display Board)

Figure 34 on page 63 for PD755

Figure 35 on page 63 for PD756

Figure 36 on page 64 for PD757

Jumper JP5 Position	Function
1	Enable relay 1 manual reset
2	Enable relay 2 manual reset
3	Enable relay 3 manual reset
4	Enable relay 4 manual reset

Fail-Safe Operation of Relays (Options Board)

Figure 24 on page 57 for PD755

Figure 25 on page 58 for PD756

Figure 27 on page 59 for PD757

Jumper J5 Position	Function
On	Apply fail-safe function to all relays
Off	Disable fail-safe function to all relays

Power Selection

Overview

Power Selection involves the following:

1. Changing to 230 VAC power if needed. 115 VAC is factory default on AC powered models.
2. Labeling the meter as to how it will be powered: 115 VAC or 230 VAC. Meters powered from 24 VDC are labeled as such at the factory.

Note: Meters ordered to operate from 24 VDC do not require any special setup; this option is not field selectable.



Installation and configuration must be undertaken by qualified servicing personnel.



When servicing the PD756 in a hazardous area, all appropriate hazardous area procedures must be followed.



All AC powered meters are shipped from the factory set for 115 VAC power. Do not apply 230 VAC without first setting up the Digital Temperature Meter to accept this voltage. Otherwise it will cause damage to the meter and endanger personnel.



Disconnect power prior to performing the following procedures.

All three meters are field selectable for either 115 VAC or 230 VAC power. Changing the voltage selection involves the removal of the front cover and the Display Board, then selecting 115V or 230V on switch S1 located on the Main Board.



Observe polarity for DC powered meters. Applying voltage with reverse polarity may damage the meter.



Do not apply an AC voltage to DC powered meters. Applying an AC voltage to DC powered meters will result in damage to the meter and endanger personnel.

Changing from 115 to 230 VAC Power

To access the 115/230 VAC switch it is necessary to remove the housing cover and the Display Board, see **Disassembling the Meter**, page 16.

Once the Display Board has been removed, switch S1 is visible. It is the large black component with a red slide switch on the top, located next to the transformer. For an illustration see:

Figure 31 on page 61 for PD755

Figure 32 on page 62 for PD756

Figure 33 on page 62 for PD757

For 115 VAC operation, the switch shows 115V; for 230 VAC it shows 230V.

Several setup steps are required and connections made while Display Board is removed, so it should not be reinstalled just yet. However, to avoid electric shock, install Display Board prior to applying power.

Labeling Meter for 115 VAC, 230 VAC or 24 VDC

CAUTION

ALL AC POWERED UNITS ARE SHIPPED FROM THE FACTORY SET FOR 115 VAC
(SEE INSTRUCTION MANUAL TO CHANGE VOLTAGE SELECTION)

115 VAC
 230 VAC
 24 VDC



A label on top of the unit contains a place for the user to indicate if the unit is powered from 115 or 230 VAC. User should mark the appropriate box once the desired power has been selected on switch S1.

Figure 1. Input Power Label

Connections

Overview

The following connections are made to removable screw terminal connectors supplied with each meter:

- Power Connections
- Signal Connections
- Enter, Acknowledgement, and Hold Connections
- Relays Connections
- 4-20 mA Output Connections

Connector	Location	Function	Wire Size
J1	Main Board	Signal connections	12-22
J2	Main Board	Power connections	12-18
J3	Main Board	Connections to Options Board	
J4	Main Board	Connections to Display Board	
J1	Options Board	4-20 mA output	12-22
J2	Options Board	Connections to Main Board	
J3	Options Board	Relays 1 & 2 connections	12-18
J4	Options Board	Relays 3 & 4 connections	12-18

Wiring Instructions

For connector locations, refer to:

Figure 31 on page 61 for PD755

Figure 32 on page 62 for PD756

Figure 33 on page 62 for PD757

1. All field connections to be made with insulated copper wire, either solid or stranded. Tighten all screw terminals to 4.5 lb-in (0.5 Nm). Strip length = ¼ in (7 mm). **DO NOT** pre-treat wire with solder.
2. **Terminals L1(V+), L2(V-) on J2, Main Board, Earth Ground, and terminals 1-6 on J3-J4, Options Board:** Use AWG #12-18 wire, 600 volt, 60°C. Connect only one wire to each terminal.
3. **Terminals EN, AK, H, CM, P-, P+, EX, +, -, on J1 Main Board and terminals +, - on Options Board:** Use AWG #12-22 wire, 150 volt, 60°C. If using AWG #20 or smaller wire, up to two wires may be connected to each terminal. If using AWG #18 or larger wire, only one wire may be connected to each terminal.
4. Install conduit hubs to the enclosure cable input ports. To maintain NEMA 4X rating use only UL/CSA watertight conduit hubs.
5. Feed all wires through the enclosure cable input ports.
6. Remove one connector at a time from the headers and connect the wires to the connector.
7. After wiring a connector, insert it back into the header.

Terminals Designation

Terminal	Description
L1, L2, Gnd	AC input power
V+, V-	DC input power
EN	External Enter
AK	External relay acknowledge
H	Hold reading
CM	Common (return) for AK, EN, & H

Terminal	Description
P+, P-	24 VDC supply
EX	Excitation for RTD
+, - (Main Board)	TC & RTD input
+, - (Options Board)	4-20 mA output (see page 27)
1-6 (Option Board)	Relays 1-4 (see page 27)

Power Connections



When servicing the PD756 in a hazardous area, all appropriate hazardous area procedures must be followed.



Refer to **Changing from 115 to 230 VAC Power**, page 20 to make sure meter is set up to accept proper voltage before applying power.



Disconnect power to the meter before making any connections.



Do not connect Power or Earth Ground to any unused or CM terminals.



Connecting 230 VAC with 115 VAC selected will result in damage to the instrument as well as endanger personnel. Connecting AC power when meter is set up for DC power will result in damage to the instrument as well as endanger personnel.

Connect power to terminals L2(V-) and L1(V+) on screw terminal connector J2, located near the transformer on the Main Board. Connect Earth Ground to screw terminal marked with Ground symbol located on enclosure's base for PD756 and 757. Ground terminal for PD755 is located on J2 connector.

Figure 31 on page 61 for PD755

Figure 32 on page 62 for PD756

Figure 33 on page 62 for PD757

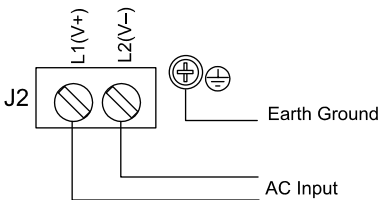

Wiring Diagram for AC Power

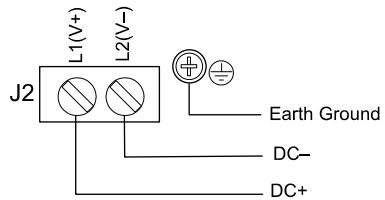

Wiring Diagram for DC Power

Figure 2. Input Power Connections for 756 and 757

Notice:

- Primary voltages must not be accessible to the user.
- Primary wires must be installed in accordance to the applicable standards.
- Keep the primary wires separated from signal cables.

Signal Connections

Signal connections are made to a 10-position connector J1 on the Main Board. This connector also includes connections for Enter, Acknowledgement, Hold Reading, and Common. For location of J1, refer to:

Figure 31 on page 61 for PD755.

Figure 32 on page 62 for PD756.

Figure 33 on page 62 for PD757.

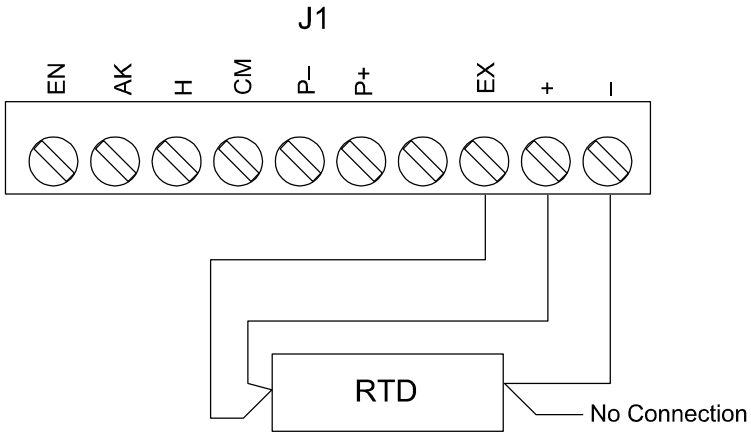

Figure 3. Four-Wire RTD Connections

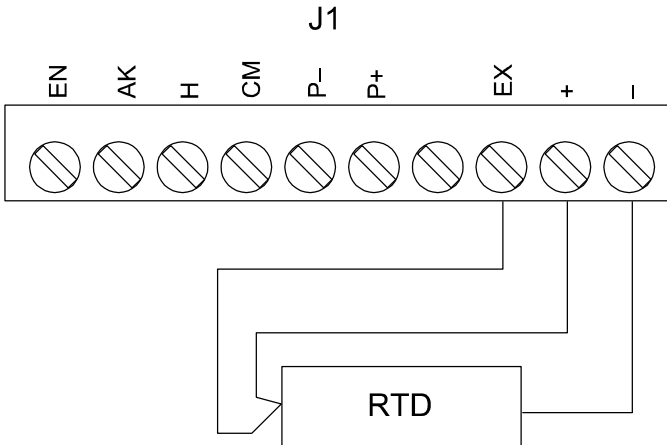

Figure 4. Three-Wire RTD Connections

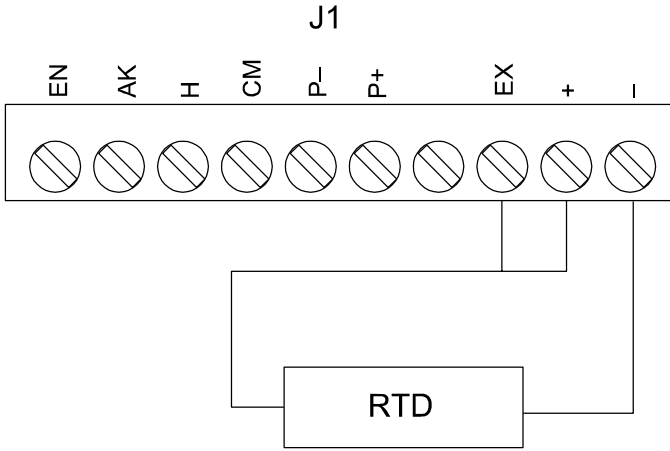

Figure 5. Two-Wire RTD Connections

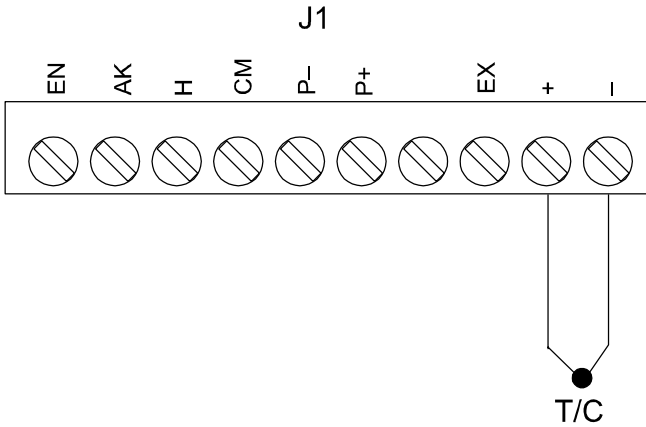

Figure 6. Thermocouple Connections

Enter, Acknowledgement, and Hold Connections

Enter, acknowledgement, and hold terminals on J1 (Main Board) provide a convenient method to remotely access the following functions:

Terminal	Function
EN	Programs meter via the front panel menu
AK	Acknowledges or resets relays, exit menu scroll
H	Holds the temperature reading

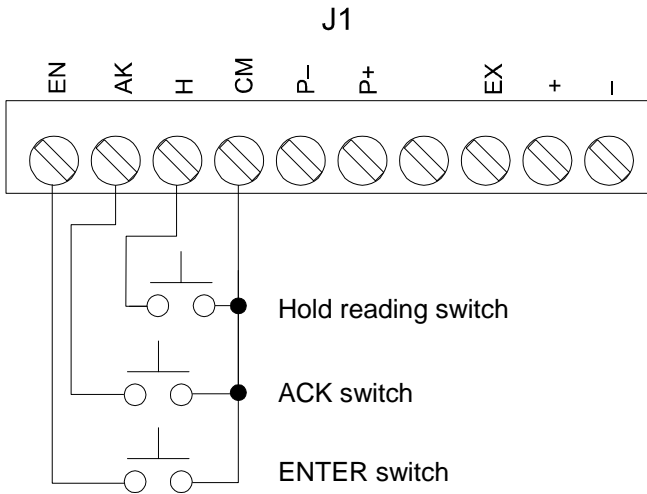

Figure 7. External Control Connections

Optional Relays & 4-20 mA Output Terminals

Depending on model number, Options Board may contain 2 or 4 relays and/or an isolated 4-20 mA output transmitter. Relay connections are made to removable screw terminal connectors located at J3 and J4 on the Option Board. Connections for the isolated 4-20 mA output option are made to J1 on the Options Board. For location of connectors, refer to:

Figure 24 on page 57 for PD755.

Figure 25 on page 58 for PD756.

Figure 27 on page 59 for PD757.

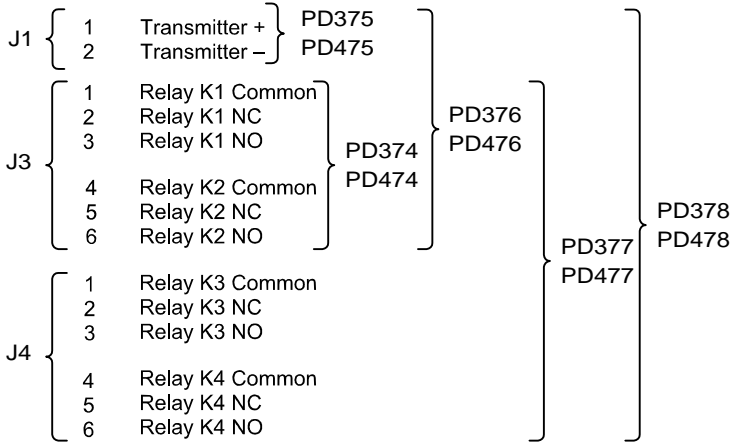

Figure 8. Relay and 4-20 mA Output Terminals

Isolated 4-20 mA Output Transmitter Connections

The Digital Temperature Meter can be equipped with an optional isolated 4-20 mA output transmitter that can be programmed to produce a 4-20 mA signal for virtually any temperature span displayed. For best performance, a 500-count span is recommended between the 4 and 20 mA outputs. (Ex. 0.0°C = 4 mA, 50.0°C = 20 mA).

The following diagrams illustrate the 4-20 mA output signal being powered from the Digital Temperature Meter's internal power supply (AC powered meters only) and by an external power supply.

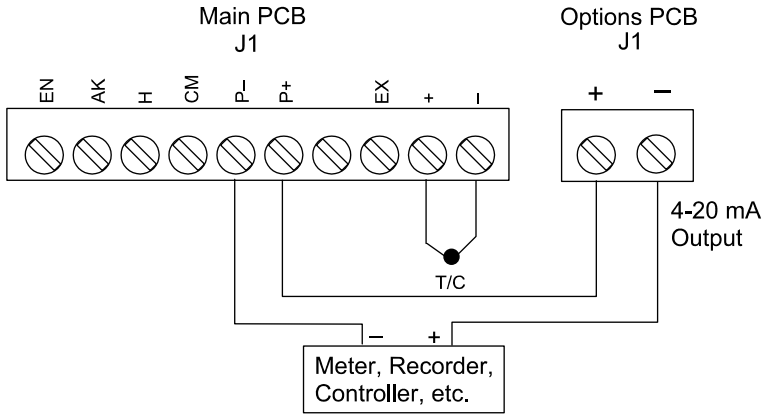

Figure 9. Output Loop Powered by Meter

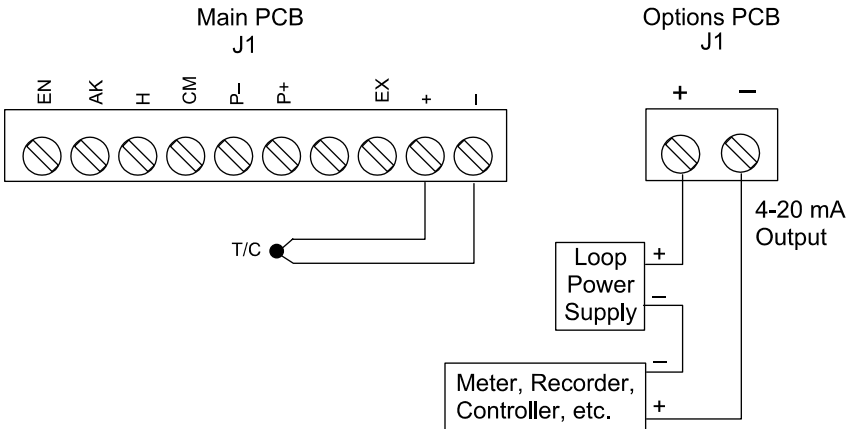

Figure 10. Output Loop Powered from External Power Supply



If the output loop is powered by an external supply, the loop power supply must be turned on before the meter is turned on. Otherwise, the output loop signal may be incorrect.

Programming

Overview

This section of the manual deals with programming the following aspects of the meter:

- Basic Meter
- Alarm Set Points
- 4-20 mA Output
- Lockout Jumper

The Digital Temperature Meter is programmed after setting three jumper arrays, see **Jumper Configuration** on page 19. The **ENTER** button is used to program all the meter functions and to display useful information.

The jumper arrays are used for setting the input (thermocouple or RTD), lockout, relay acknowledge enable (ACK), and relay fail-safe operation.

Jumper Arrays

Jumper Array Function	Label	Location
Input signal T/C or RTD	JP1	Main Board
Lockout	JP2	Main Board
Relay ACK enable	JP5	Display Board
Fail-safe	J5	Options Board

For jumper array location see:

Figure 31 and Figure 34 on pages 61, 63 for PD755.

Figure 32 and Figure 35 on pages 62, 63 for PD756.

Figure 33 and Figure 36 on pages 62, 64 for PD757.

If the optional relay Board is installed, it is best to program the fail-safe jumper (J5 on Options Board) for the desired operation before reassembling the Display Board because this jumper is not accessible once the Display Board is installed.

Select Type of Input Signal T/C or RTD

The Digital Temperature Meter can accept either thermocouples or RTD inputs, using jumper JP1 located on the Main Board.

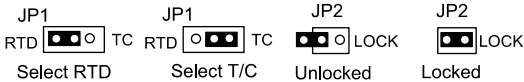

Figure 11. JP1 Input Signal Selection Array.

The Digital Temperature Meter can be programmed to restrict personnel from making changes to the programmed parameter settings; this is accomplished by installing a jumper over LOCK pins on JP2.

ENTER Button Functionality

The **ENTER** button is used to program the meter for various functions, is located on the Display Board and is labeled SW2. The **ENTER** button on PD755 can be accessed from the front panel. The **ENTER** button on models 756 and 757 can only be accessed with the front panel removed. The **ENTER** button can also be accessed by wiring a normally open pushbutton switch across terminals EN and CM on connector J1 located on the Main Board (see Figure 7 on page 26).

ACK Button Functionality

The **ACK** button is used to acknowledge the relays when the meter is in reading mode and to quit the menu scroll in programming or diagnostic. If **ENTER** has been pressed and the meter is scrolling down the menu, pressing **ACK** button returns meter to reading mode, it does not acknowledge relays during menu scroll.

Magnetic Reed Switch Functionality

The PD756 has two magnetic reed switches located above the **ENTER** and **ACK** buttons. The reed switches allow the user to program and operate the meter without having to remove the enclosure cover.

To operate the reed switches, move the magnet assembly (PDA-MAG) toward and away from the glass window, just above the **ENTER** and **ACK** buttons. The action is detected when the magnet is moved away from the glass window. Moving the magnet toward and away from the glass window produces the same results as pressing the front panel buttons.

The PD756 can be programmed and operated in three different ways:

1. Using front panel push buttons.
2. Using external push buttons wired to J1 connector. Explosion-proof control stations are required when used in a hazardous area.
3. Using magnet assembly to operate the reed switches.

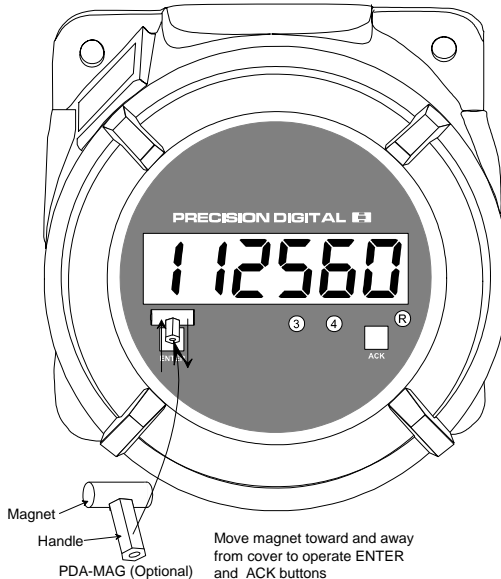

Figure 12. Reed Switch Operation

General Programming Description

When power is applied to the meter, the display flashes **188888**, then it displays the temperature from the sensor.

To program the meter lockout jumper JP2 must be removed.

After pressing the **ENTER** button, the display will scroll through the following functions in the order shown:

Display	Type of Function
H I t	Displays maximum temperature
L O t	Displays minimum temperature
CAL Ib	Calibrates meter for selected input type.
OFFSEt	Sets offset value to the input, negative or positive
tYPE	Sets the type of T/C or RTD to be used
F or C	Sets temperature scale, Fahrenheit or Celsius
SEtUP	Sets alarm set points for latching or non-latching operation
SEtPtS	Sets alarm set and reset points.
outPut	Sets 4 and 20 mA output points, if this option is installed.
d IAg	Displays parameter settings one at a time for diagnostic purposes.

Five Basic Digit/Display-Setting Instructions

1. If flashing display is OK, press **ENTER** to accept it, before display stops flashing.
2. If flashing display is not OK, (or if **ENTER** was not pressed in time to accept it), wait for the first digit to flash.
3. If a flashing digit is OK, press **ENTER** to accept it, before it starts to scroll.
4. If a flashing digit is not OK, (or if **ENTER** was not pressed in time to accept it) wait for digit to scroll, and press **ENTER** when OK.
5. Digits will scroll until **ENTER** is pressed. When a digit is accepted by pressing **ENTER**, next digit flashes.

Programming the Basic Meter

Programming the basic meter consists of selecting the type of T/C or RTD and selecting the temperature scale °F or °C.

The Digital Temperature Meter must be programmed for the type of thermocouple or RTD it is to accept. Selecting the wrong type will cause an incorrect temperature to be displayed.



Connect the thermocouple or RTD to J1 on the Main Board.

Using the **TYPE** menu, enter a number from 0 to 10, this number defines the type of thermocouple or RTD input required and the display resolution. The following table is used to define the types:

Type Number	Type of Input	Range	Accuracy
0	Type J T/C	-328° to 1382° F -200° to 750°C	±2°F ±1°C
1	Type K T/C	-328° to 2498°F -200° to 1330°C	±2°F ±1°C
2	Type T T/C	-330° to 760°F -200° to 404°C	±2°F ±1°C
3	Type T T/C (0.1°)	-330.0° to 760.0°F -200.0° to 404.0°C	±2°F ±1°C
4	Type E T/C	-328° to 1832°F -200° to 1000°C	±2°F ±1°C
5	Type R T/C	32° to 3213°F 0° to 1767°C	±5°F ±3°C
6	Type S T/C	40° to 3214°F 4° to 1768°C	±6°F ±3°C
7	100 Ω RTD (0.00385, 0.1°)	-328.0° to 1382.0°F -200.0° to 750.0°C	±0.7°F ±0.4°C
8	100 Ω RTD (0.00392, 0.1°)	-328.0° to 1382.0°F -200.0° to 750.0°C	±0.7°F ±0.4°C
9	100 Ω RTD (0.00385, 1°)	-328° to 1382°F -200° to 750°C	±1°F ±1°C
10	100 Ω RTD (0.00392, 1°)	-328 to 1382°F -200° to 750°C	±1°F ±1°C



Selecting Type of T/C or RTD (TYPE)

After power is applied to the meter, the display will indicate a temperature reading, which might be incorrect since the meter could be programmed for a different type of thermocouple or RTD.

Press ENTER to begin scrolling through the functions.		62F
When TYPE (type) appears, press ENTER .		TYPE
The meter now displays the type choices starting at the previously programmed number; here it is type 6. The number starts to increase up to type 10 and then goes to type 0. Select the type number from the previous table.		TYPE 6
Press ENTER when the desired type number appears. In this case, it is type 0 for type J T/C.		TYPE 0
The meter will then display F or C Press ENTER to select scale.		F or C
Press the ACK button to quit menu scroll and return to indication mode. The meter is now displaying the process temperature accurately.		72F

Select °F or °C (F or C)

The Digital Temperature Meter will display temperature in either Fahrenheit or Celsius scale.

Set or change the temperature scale Press ENTER to begin scrolling through the functions.		72F
When F or C (°F or °C) appears, press ENTER .		F or C
The display will show F for Fahrenheit and C for Celsius; they will flash alternately. Select one when it is flashing by pressing ENTER .		F or C
The display will indicate the temperature in the selected scale.		22C

Note:

Whenever a programmed setting is changed in the basic meter, the offset value is reset to zero and the max/min readings are reset to the actual temperature reading. Alarm setup, set points, and 4-20 mA output programming do not reset these settings.

Alarm Setup and Set Points Programming

Overview

The Digital Temperature Meter is available with four alarm points and corresponding front panel status LEDs as a standard feature. The front panel LEDs are useful for alarm applications that require visual notification only. For applications that require relay contacts, such as driving external alarm devices or on/off temperature control, the Digital Temperature Meter can be equipped with either two or four relays. Any of these relays may be assigned to set and reset at predetermined temperatures. Each relay can be set up for latching or non-latching operation independently.

Programming the relays involves four steps:

1. Setting the relay manual reset (ACK enable) jumpers.
These jumpers (JP5) are located on the Display Board and determine if a relay can be manually reset.
2. Setting the fail-safe jumper (J5).
Fail-safe mode (default): In the alarm condition, the NC contacts are connected to the Common (C) contacts of the relays. The fail-safe operation can be disabled, by removing jumper J5 located on the Options Board.
3. Setting the alarm set points for latching or non-latching relay operation using **SEt uP** menu.
4. Setting set and reset points using **SEt PtS** menu.
 - a. Setting set points for alarms.
 - b. Setting reset points for alarms.

Set Relays for Manual or Automatic Reset

Jumper array JP5 located on the Display Board is used to program the relays so they can be reset manually. For location of JP5 on the Display Board, see:

Figure 34 on page 63 for PD755.

Figure 35 on page 63 for PD756.

Figure 36 on page 64 for PD757.

Set Relays for Fail-Safe Operation

In fail-safe mode, the relay coils are *energized* and the Normally Open (NO) contacts are connected to the Common (C) contacts under normal operation. During an alarm condition, the relay coils are *de-energized*, the Normally Closed (NC) contacts are connected to the Common (C) contacts. During power failure, the relay contacts reflect an alarm condition.

Removing jumper J5 disables the fail-safe operation. J5 is located on the Options Board next to the J2 connector. For location of J5 on the Options Board, see:

Figure 24 on page 57 for PD755

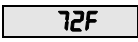



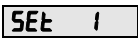
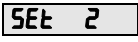
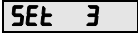
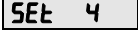





Figure 25 on page 58 for PD756

Figure 27 on page 59 for PD757

If fail-safe mode is disabled, operation of the relay contacts is opposite to the one described in the previous paragraph.

Setup for Latching or Non-Latching Relays (SEtUP)

Each alarm set point can be set up for latching or non-latching relay operation independently. This means that a combination of latching and non-latching relays could be used in this meter. Factory default is non-latching operation for all relays.

<p>Note To simplify programming, write down the desired programming values prior to attempting to program the meter. The Programmed Parameter Settings form, located on page 69, provides a convenient method to record the user settings; it also provides the factory setting for most of the programmable parameters.</p>		
<p>Press ENTER to begin scrolling through the functions.</p>		
<p>When setup (SEtUP) appears, press ENTER.</p>		
<p>The display scrolls through SEt 1, SEt 2, SEt 3, and SEt 4 for set point 1 through set point 4 setup. Press ENTER to select latching or non-latching relay operation for desired set point. If ENTER is pressed while scrolling set points, LAtCH is displayed for 3 seconds.</p>		 then  then  then 
<p>Press ENTER to program set point for latching or non-latching relay operation when LAtCH is displayed.</p>		
<p>y or n flashes alternately. Press ENTER when appropriate letter is flashing to make selection. After selection is made, display shows next set point or next menu function.</p>		 then 
<p>Press ACK button to exit menu scroll and return to reading mode or wait until meter scrolls through the entire menu. The display will return to indicate the temperature.</p>		

Alarm Set and Reset Points Programming

Alarm set and reset point values are programmed under the set points (**SETPts**) menu, one at a time, starting with alarm #1 set point.

The four discrete LEDs on the display indicate which alarm point is being programmed. There are two LEDs on the display Board labeled **S** and **R**, they indicate whether a set or reset point is being programmed

Each alarm will have a set point programmed first, and then the reset point is programmed.

Each alarm set point may be programmed for either a high alarm or a low alarm with 0-100% deadband.

To program a high alarm:

Program the set point above the reset point.

To program a low alarm:

Program the set point below the reset point.

To program the alarm deadband:



Program the reset point above or below the set point by an amount equal to the desired deadband value.

Example:

Alarm 2 is a high alarm that trips at 1500° and has a deadband of 100°.

Alarm 2 set point is set at 1500° and its reset point at 1400°.

Programming Alarm Points Using Set Points (SEtPt5) Menu

<p>Note To simplify programming, write down the desired programming values prior to attempting to program the meter. The Programmed Parameter Settings form, located on page 69, provides a convenient method to record the user settings; it also provides the factory setting for most of the programmable parameters.</p>		
<p>Press ENTER, then press ENTER again when set points (SEtPt5) function appears. The display will scroll through the set points. Press ENTER when the desired set point is displayed to program that set point.</p>		<div style="border: 1px solid black; padding: 2px; display: inline-block;">SEtPt5</div>
<p style="text-align: center;">To program set points values</p> <p>The display scrolls through SEt 1, SEt 2, SEt 3, SEt 4, for alarm set point 1 through alarm set point 4. Press ENTER when desired set point appears.</p> <p>After SEt 4 is displayed or programmed, the meter will exit the SEtPt5 (set points) menu and move to the next programming menu.</p> <p>outPut will be displayed, if 4-20 mA transmitter output option is installed.</p>		<div style="border: 1px solid black; padding: 2px; display: inline-block;">SEt 1</div> then <div style="border: 1px solid black; padding: 2px; display: inline-block;">SEt 2</div> then <div style="border: 1px solid black; padding: 2px; display: inline-block;">SEt 3</div> then <div style="border: 1px solid black; padding: 2px; display: inline-block;">SEt 4</div> then <div style="border: 1px solid black; padding: 2px; display: inline-block;">outPut</div>
<p>If ENTER is pressed while a set point is shown, the display will then show a flashing number. Program the desired set point value per Five Basic Digit/Display-Setting Instructions on page 31.</p>		<div style="border: 1px solid black; padding: 2px; display: inline-block;">SEt 1</div> then <div style="border: 1px solid black; padding: 2px; display: inline-block;">00 100F</div>

Alarm Set and Reset Programming Confirmation

To verify that the alarm set and reset points have been programmed as desired, press **ENTER**, and press **ENTER** again when **SEtPt5** appears, the display will scroll through set points 1 through 4. Press **ENTER** when the desired set point is shown. Before the display stops flashing set point value, press enter to advance the display to reset point.

Isolated 4-20 mA Output Transmitter Option

The Digital Temperature Meter can be equipped with an optional isolated 4-20 mA output transmitter that can be programmed to produce a 4-20 mA signal for virtually any temperature span displayed. For best performance, a 500 count span is recommended between the 4 and 20 mA outputs. (Ex. 0.0°C = 4 mA, 50.0°C = 20 mA).







Figure 9 and Figure 10 on page 28 show the 4-20 mA output signal being powered from the Digital Temperature Meter's internal 24V power supply (AC powered meters only) and by an external power supply.

To program the 4-20 mA output, a temperature display is programmed to produce the 4 mA signal. Another temperature display, (higher or lower than the one set for the 4 mA point), is programmed to produce the 20 mA signal. The output will be linear as the temperature changes from the 4 mA setting to the 20 mA setting.

Example: If the 4 mA point is set for 0°, and the 20 mA point is set for 1000°, the output will be 6 mA when the temperature display reads 125°.

Note: The 4-20 mA output is driven by the number been displayed. It doesn't adjust itself if the temperature scale is changed.

4-20 mA Output Programming (*outPut*)

<p>Press ENTER, then press ENTER again when the output (<i>outPut</i>) menu appears.</p>	 
<p>Set the display for the value at which 4 mA is produced The green LED labeled "4" will be on indicating the meter is ready to accept the value at which 4 mA is produced. After the display corresponding to 4 mA is accepted, an LED labeled "20" turns on. For instructions, see <i>Five Basic Digit/Display-Setting</i> Instructions on page 31.</p>	 <p>final</p> 
<p>Set the display for value at which 20 mA is produced The green LED labeled "20" will now be on indicating the meter is ready to accept the value at which 20 mA is produced. Program this value in the same fashion as was done above.</p>	 <p>final</p> 

4-20 mA Output Programming Confirmation

The values that have been programmed to produce the 4 and 20 mA outputs can be quickly checked to make sure they are the desired values. To do this, access the *outPut* routine by pressing **ENTER**, and then pressing **ENTER** again when *outPut* appears.

The green "4" LED illuminates indicating the meter is displaying the value at which it will produce a 4 mA output. Confirm that this is the desired value. Press **ENTER**, the green "20" LED illuminates indicating the meter is displaying the value at which it will produce a 20 mA output. Confirm that this is the desired value. Press **ENTER** (within 3 seconds), before the entire display stops flashing and the meter returns to indication mode.

Input Offset Adjustment (**OFFSEt**)

This parameter allows the user to select an offset to the input signal being displayed. Offset values can be either positive or negative and can be any number within the range of the display. The offset value is programmed through the offset (**OFFSEt**) menu.

The offset feature can be useful to compensate for errors due to thermocouple junctions or excessive lead wire resistance in RTDs.

The offset value is factory default to zero. The offset value is automatically reset to zero whenever a programmed parameter, related to the temperature display, is changed.

To program the offset value follow instructions described in,

Five Basic Digit/Display-Setting Instructions on page 31.

Program input offset		
<p>Press ENTER, when OFFSEt appears press ENTER again to program input offset value.</p> <p>Example: If display reads 85°F when the actual temperature is 80°F, program an offset value equal to -5°F. Then the display will indicate the actual temperature.</p>		<div style="border: 1px solid black; padding: 2px; display: inline-block; margin-bottom: 5px;">85F</div> then <div style="border: 1px solid black; padding: 2px; display: inline-block; margin-bottom: 5px;">OFFSEt</div> then <div style="border: 1px solid black; padding: 2px; display: inline-block; margin-bottom: 5px;">00000F</div> then <div style="border: 1px solid black; padding: 2px; display: inline-block; margin-bottom: 5px;">-0005F</div> then <div style="border: 1px solid black; padding: 2px; display: inline-block;">80F</div>

Lockout Jumper

The Lockout jumper is used to restrict modification of calibration and programming values. It is labeled “LOCK” on JP1 (see Figure 11 on page 29).

The lockout feature allows viewing only of the alarm settings and temperature points programmed to produce the 4 and 20 mA output signals.

The following menu functions are still available with the lockout jumper installed.

Display	Type of Function
H I t	Displays maximum temperature.
LO t	Displays minimum temperature.
CLERr	Clears (resets) maximum or minimum temperatures reached by the process.
SEtPtS	Displays alarm set and reset points.
outPut	Displays 4 and 20 mA output points, if this option is installed.
d iAg	Displays parameter settings one at a time for diagnostic purposes. Press ACK to exit diagnostic menu at any time.

OPERATION

Overview

The Large Display Temperature Meter accepts the J, K, T, E, R, and S thermocouples and 100 Ω platinum RTDs as inputs. The meter will display the temperature in either Fahrenheit or Celsius scales on a 4½ digit display. Options include up to four relays for external switching at alarm points as well as an isolated 4-20 mA transmitter output.

The front panel consists of six seven-segment LEDs as well as eight programming/operational LEDs. The programming/operational LEDs provide the following indication:

LED	During Programming	During Operation
1	Alarm 1	Alarm 1
2	Alarm 2	Alarm 2
3	Alarm 3	Alarm 3
4	Alarm 4	Alarm 4
S	Set point indicator	None
R	Reset point indicator	None
4	4 mA output indicator	None
20	20 mA output indicator	None

Refer to Figure 37 on page 65 for PD755.

Refer to Figure 38 on page 65 for PD756.

Refer to Figure 39 on page 65 for PD757.

The four alarm status LEDs indicate alarm condition only and do not represent relay status when set points are set up for non-latching relay mode. For instance, if alarm 1 is programmed for a high alarm at 500 with manual reset of the relays. If the operator resets the relays when the display reads 650, LED #1 will stay on until the display falls below 500.

Set points set up for latching relay mode will reflect the status of the LEDs, regardless of the status of the alarm condition. For instance, when a latching relay is acknowledged the corresponding status LED will extinguish.

Another example:

- With manual reset of the relays enabled.
- Alarm 1 set up as non-latching and programmed for high alarm.
Set at 100
Reset at 50
- If the operator resets the relays when the display reads 80.
- LED 1 will stay on until the display falls below 50.

Basic Meter Operation





Overview

In its most basic form, the Digital Temperature Meter provides process temperature display with visual alarm indication. It captures the maximum and minimum process temperature and displays it through the **H I t** and **LO t** menu functions. The maximum and minimum captured temperatures can be reset, after they are displayed, through the **CLEAR** menu function.

The diagnostic feature (**d IAS**) provides an easy way to view and write down the parameter settings for troubleshooting purposes. Press **ENTER** to step through the functions and settings, press **ACK** to exit at any time.

Maximum/Minimum Temperature Display

The maximum and minimum temperatures reached by the process are store in memory until cleared (reset) by the user or until power is turned off to the meter. Max/min temperatures are displayed via the **ENTER** button and **H I t**/**LO t** menu functions respectively. Max/min values are reset whenever a programmed setting, relative to temperature display, is changed.

Display maximum and minimum temperatures		
<p>Maximum temperature</p> <p>Press ENTER, the first function displayed is H I t, press ENTER again to display the maximum temperature reached by the process since last reset. Maximum temperature will be displayed for 3 seconds, then display will show flashing CLEAR.</p>		<div style="border: 1px solid black; padding: 2px; text-align: center;">500F</div> <p style="text-align: center;">then</p> <div style="border: 1px solid black; padding: 2px; text-align: center;">H I t</div> <p style="text-align: center;">then</p> <div style="border: 1px solid black; padding: 2px; text-align: center;">725F</div>
<p>Reset maximum temperature</p> <p>After maximum temperature is displayed, CLEAR function appears. Press ENTER to reset maximum temperature in memory or press ACK to exit without resetting value in memory.</p>		<div style="border: 1px solid black; padding: 2px; text-align: center;">CLEAR</div>
<p>Minimum temperature</p> <p>Press ENTER when LO t is displayed to display minimum temperature reached by the process since last reset. Minimum temperature will be displayed for 3 seconds, then display will show flashing CLEAR.</p>		<div style="border: 1px solid black; padding: 2px; text-align: center;">500F</div> <p style="text-align: center;">then</p> <div style="border: 1px solid black; padding: 2px; text-align: center;">LO t</div> <p style="text-align: center;">then</p> <div style="border: 1px solid black; padding: 2px; text-align: center;">475F</div>
<p>Reset minimum temperature</p> <p>After minimum temperature is displayed, CLEAR function appears. Press ENTER to reset maximum temperature in memory or press ACK to exit without resetting value in memory.</p>		<div style="border: 1px solid black; padding: 2px; text-align: center;">CLEAR</div>
<ul style="list-style-type: none"> Pressing ENTER while Max/min values are being displayed advances display to CLEAR. Pressing ACK at any time in the above-described operations exits to reading mode. 		

Relays Operation

Overview

The relay option added to the Digital Temperature Meter expands its usefulness beyond simple indication to provide users with alarms and simple on/off temperature controlling functions. There are two basic ways the relays can be used:

1. High or low alarms with latching or non-latching relay operation.
2. Simple on/off temperature control with 100% adjustable deadband.

Relays Auto Initialization

When power is applied to the meter, the front panel LEDs and alarm relays will reflect the state of the input to the meter. For instance, if the meter is powered up and reads 500, the following table indicates how the alarm LEDs and relays will react based on the various set and reset points:

Alarm #	HI or LO	Set Point	Reset Point	Power-Up Reading	Relay & LED
1	HI	1000	500	499	Off
2	LO	700	900	500	On
3	LO	250	400	500	Off
4	HI	450	200	500	On

Fail-Safe Operation

The following table indicates how the relays behave based on Jumper J5 being installed or not installed:

Jumper J5 on Options Board	Fail-Safe	Relay coils Energized in	Power Failure
On	Enabled	Non-alarm state	Relays go to alarm state
Off	Disabled	Alarm state	Relays go to non-alarm state

Front Panel LEDs

Refer to Figure 37 on page 65 for PD755.

Refer to Figure 38 on page 65 for PD756.

Refer to Figure 39 on page 65 for PD757.

The LEDs on the front panel provide status for the following:

LED	Status
1	Alarm 1
2	Alarm 2
3	Alarm 3
4	Alarm 4

LED	Status
S	Set point indicator
R	Reset point indicator
4	4 mA indicator
20	20 mA indicator

The Digital Temperature Meter is supplied with four alarm points that include front panel LEDs to indicate alarm conditions. This standard feature is particularly useful for alarm applications that require visual-only indication. The front panel LEDs are controlled by the set and reset points programmed by the user and the acknowledge function in latching relay operation. When the display passes a set point for a particular alarm, that alarm's LED will light up. When the meter passes back through that alarm's reset point the LED will go off if alarm point was set up for non-latching operation.

Alarm status LEDs respond differently for latching and non-latching relays.

For non-latching relays, LEDs are always off during normal condition and always on during alarm condition, regardless of state of the relay.

For latching relays, LEDs reflect state of the relays, regardless of the alarm condition. The following tables illustrate how the alarm LEDs function in relation to the relays and the acknowledge button:

Relay key legend for following tables

Key	Relay condition
On	Tripped
Off	Reset
Ack	Acknowledged

The On and Off keys do not refer to the status of the relay's coil, which depends on the fail-safe mode selected.

Non-Latching Relay

Automatic reset only JP5(1-4 off)

Condition	LED	Relay
Normal	Off	Off
Alarm	On	On
Ack (No effect)	On	On
Normal	Off	Off

In this application, the meter is set up for automatic reset and non-latching relay. Acknowledging the alarm while it is present has no effect on either the LED or the relay. When the alarm finally goes away, the relay automatically resets and the LED goes off.

Non-Latching Relay**Automatic + manual reset at any time JP5(1-4 on)**

Condition	LED	Relay
Normal	Off	Off
Alarm	On	On
Normal	Off	Off

In this application, the meter is set up for automatic + manual reset at any time and non-latching relay. The LED and the relay automatically reset when the meter returned to the normal condition.

Automatic + manual reset at any time JP5(1-4 on)

Condition	LED	Relay
Normal	Off	Off
Alarm	On	On
Ack	On	Off
Normal	Off	Off

In this application, the meter is also set up for automatic + manual reset at any time. However, this time, an operator acknowledges the alarm manually while it still exists. This causes the relay to reset, but the LED stays on until the meter returns to the normal condition. Remember, for non-latching relays, the LED is always OFF during normal condition and always ON during alarm condition, regardless of the state of the relay.

Latching Relay

Manual reset only after signal passes reset point JP5(1-4 off)

Condition	LED	Relay
Normal	Off	Off
Alarm	On	On
Ack (No effect)	On	On
Normal	On	On
Ack	Off	Off

In this application, the meter is set up for manual reset only after the signal passes the reset point of the latching relay. Acknowledging the alarm while it is present has no effect on either the LED or the relay. When the alarm is acknowledged, after it returns to the normal state, the LED and the relay go off. Notice that the LED remained on; even after the meter returned to the normal condition. This is because, for latching relays, the alarm LEDs reflect the status of the relays, regardless of the alarm condition.

Manual reset only after signal passes reset point JP5(1-4 off)

Condition	LED	Relay
Normal	Off	Off
Alarm	On	On
Normal	On	On
Ack	Off	Off

In this application, the meter is set up for manual reset only after the signal passes the reset point of the latching relay. When the alarm is acknowledged, after it returns to the normal state, the LED and the relay go off.

Latching Relay

Manual reset any time JP5(1-4 on)

Condition	LED	Relay
Normal	Off	Off
Alarm	On	On
Ack	Off	Off

In this application, the meter is set up for manual reset at any time. Acknowledging the alarm even if the alarm condition is present resets the relay and turns off the LED.

Acknowledging Relays

There are two ways to acknowledge relays programmed for manual reset: via the front panel ACK button and remotely via a switch wired across AK and CM terminals on the Main Board. When the ACK button or a switch wired across the AK and CM terminals is closed, all relays programmed for manual reset will reset.

Switching Inductive Loads

The relay contacts on the Options Board are already protected with suppression components (snubbers).

If additional suppression is required, this suppression can be obtained with RC networks assembled by the user or purchased as a complete assembly. Refer to the following circuits for RC network assembly and installation:

AC and DC Loads

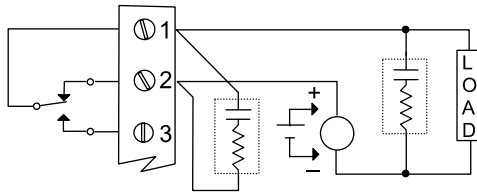

Figure 13. AC and DC Loads Protection

Choose R and C as follows:

R: 0.5 to 1 Ω for each volt across the contacts

C: 0.5 to 1 μF for each 1 A through closed contacts

Notes:

1. Use capacitors rated for 240 VAC.
2. Snubbers may affect load release time of solenoid loads, check to confirm proper operation.
3. Install the RC network at the Digital Temperature Meter's relay screw terminals. An RC network may also be installed across the load, experiment for best results.

Low Voltage DC Loads

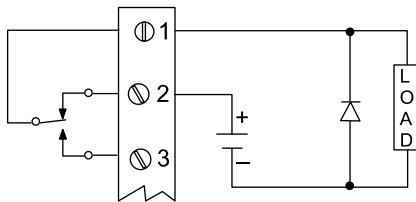

Figure 14. Low Voltage DC Loads Protection

Note: Use a diode with a reverse breakdown voltage two to three times the circuit voltage and forward current at least as large as the load current.

4-20 mA Output Operation







The Digital Temperature Meter can be equipped with an isolated 4-20 mA output option that can be programmed to produce a 4-20 mA signal between any two temperature values.

RECALIBRATION (CAL 1b)

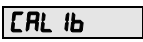
The Digital Temperature Meter is precalibrated for six types of thermocouples and two types of 100 Ω RTD sensors. These input ranges may be recalibrated and should be checked every 12 months.

Calibration is performed from the front panel using the **ENTER** button. The lockout jumper JP2 must be removed to gain access to the calibration menu, see **Input Selection and Lockout Jumpers (Main Board)**, on page 19. The only equipment needed is a thermocouple calibrator or a 5-decade resistance box with an accuracy of about 0.1% and a minimum resistance step of 0.01 Ω for RTD calibration.

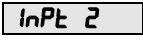
Before attempting to calibrate the meter, make sure type selected and input signal wires are correct. Using the wrong type selection or the wrong T/C wire will cause inaccurate temperature readings.

<p>Note To simplify programming, write down the desired programming values prior to attempting to program the meter. The Programmed Parameter Settings form, located on page 69, provides a convenient method to record the user settings; it also provides the factory setting for most of the programmable parameters.</p>		
<p>Press ENTER, then press it again when calibrate (CAL 1b) function appears.</p>		
<p>Input 1 (InPt 1) will flash. Apply the input corresponding to the low calibration point. Here, in this example calibration points will be 32°F and 1000°F. It is recommended to set the calibration points outside the minimum and maximum expected temperature readings. Press ENTER.</p>		
<p style="text-align: center;">Set the low calibration</p> <p>For instructions, see Five Basic Digit/Display-Setting Instructions on page 31. After low calibration point has been programmed, the display will flash InPt 2.</p>	 <p style="text-align: center;">final</p> 	
<p>Input 2 (InPt 2) will flash. Apply the input corresponding to the high calibration point. Press ENTER.</p>		
<p style="text-align: center;">Set the high calibration point</p> <p>The procedure used to set the low calibration point is the same for the high calibration point. In this example we will set it for 1000°F. After high calibration point has been programmed, display moves to the next menu function.</p>		

Calibration Error (Error)

A meter display of **Error** during calibration indicates that the calibration process was not successful. The meter should be recalibrated.

The **Error** message will appear if input 1 and input 2 signals are too close together.

The **Error** message will appear if input 1 signal is inadvertently applied for input 2 calibration signal, or **ENTER** is pressed before applying input 2.

In all cases, if an error message appears, previous calibration points will be retained in memory.

Recommended Calibration Points

To calibrate the meter, it is recommended to use the Fahrenheit scale; this will give a greater degree of accuracy to the calibration. The scale can be changed to the Celsius scale after calibration is complete; the meter will display temperature accurately in any scale. The following table shows the recommended low and high calibration points for all types.

Type Number	Type of input	Input 1 (Low)	Input 2 (High)	Check (Middle)
0	Type J T/C	32°F	1182°F	600°F
1	Type K T/C	32°F	1893°F	960°F
2	Type T T/C	32°F	693°F	360°F
3	Type T T/C	32.0°F	693.0°F	360.0°F
4	Type E T/C	32°F	1652°F	840°F
5	Type R T/C	100°F	3000°F	1500°F
6	Type S T/C	100°F	3000°F	1500°F
7	100 Ω RTD (0.00385, 0.1°)	32.0°F 100Ω	1148.0°F 320.12Ω	590.0°F 215.61Ω
8	100 Ω RTD (0.00392, 0.1°)	32.0°F 100Ω	1127.0°F 320.89Ω	580.0°F 215.87Ω
9	100 Ω RTD (0.00385, 1°)	32°F 100Ω	1148°F 320.12Ω	590°F 215.61Ω
10	100 Ω RTD (0.00392, 1°)	32°F 100Ω	1127°F 320.89Ω	580°F 215.87Ω

Minimum Input Span

Minimum span between input 1 and input 2 signals is 5 mV; consult a thermocouple table to convert mV to °F or °C for selected T/C type and specific temperature range. For RTD inputs the minimum input span is 10 Ω. The accuracy within the calibrated span will be improved, but the accuracy outside the calibrated span will not be reliable.

Calibration Verification

To verify calibration:

- Apply low calibration point signal and note reading.
- Apply high calibration point signal and note reading.
- Apply mid-scale signal and note reading.

Noted readings should be within accuracy specification for selected type. Otherwise, meter should be recalibrated for selected type and required temperature span.

INSTALLATION

The overall dimensions for the Digital Temperature Meters are shown in:

Figure 40 on page 66 for PD755.

Figure 41 on page 66 for PD756.

Figure 42 on page 67 for PD757.

Wall Mounting Instructions

PD755 Mounting

There are four mounting holes on the base of the enclosure. They are used to mount the instrument to a wall. The dimensions for the mounting holes are shown in Figure 43 on page 67.

Procedure:

1. Drill holes into the wall to accommodate suitable fasteners.
2. Remove the front bezel from the housing by removing the four mounting screws.
3. Align the enclosure mounting holes with the holes in the wall and insert the fasteners. Tighten the fasteners (see the screw mounting in Figure 44 on page 67).

PD756 Mounting

There are four mounting holes on the base of the enclosure. They are used to mount the instrument to a wall. The dimensions for the mounting holes are shown in Figure 45 on page 68.

Procedure:

1. Drill holes into the wall to accommodate the fasteners.
2. Align the enclosure mounting holes with the holes in the wall and insert the fasteners. Tighten the fasteners.

PD757 Mounting

There are four mounting holes on the rear of the enclosure. They are used to mount the instrument to a wall. The dimensions for the mounting holes are shown in Figure 46 on page 68.

Procedure:

1. Drill holes into the wall to accommodate suitable fasteners.
2. Remove the front bezel from the housing by removing the four mounting screws.
3. Align the enclosure mounting holes with the holes in the wall and insert the fasteners. Tighten the fasteners.

Panel Mounting Instructions

For applications where it is required to mount the Digital Temperature Meter into a panel, the PDA6554 and PDA6504 panel mounting kits are available for the PD755 and PD757 respectively (see **Ordering Information** on page 8).

PD755 Panel Mounting Instructions

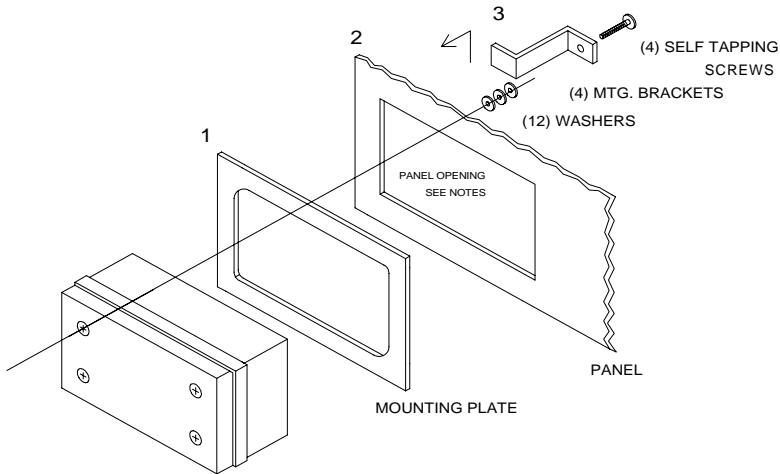

Figure 15. PD755 Panel Mounting

Instructions:

1. Insert the meter through the mounting plate.
2. Mount assembly on panel.
3. Secure with 4 brackets and 4 screws at corners of the meter.
4. Use washers as needed to allow for panel thickness.

Notes:

1. Allowable panel thickness: 0.060" – 0.125" (1.5 mm – 3.2 mm)
2. Panel cutout required: 6.62" x 5.43" (168 mm x 138 mm)
3. Mounting plate overall dimensions: 7.57" x 6.40" x 0.125" (192 mm x 163 mm x 3 mm)
4. Mounting brackets require 0.8" (20 mm) on either top or side of meter for installation.
5. This panel mounting kit is not intended to provide waterproof protection to the panel.

PD757 Panel Mounting Instructions

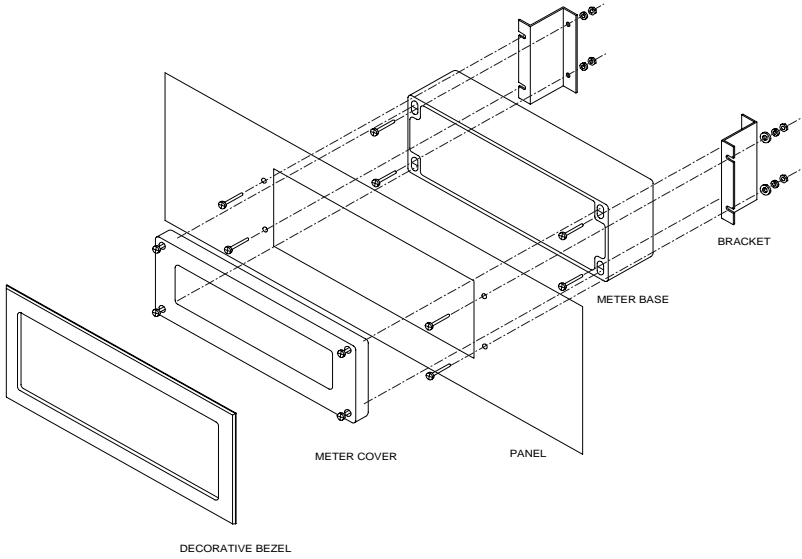

Figure 16. PD757 Panel Mounting

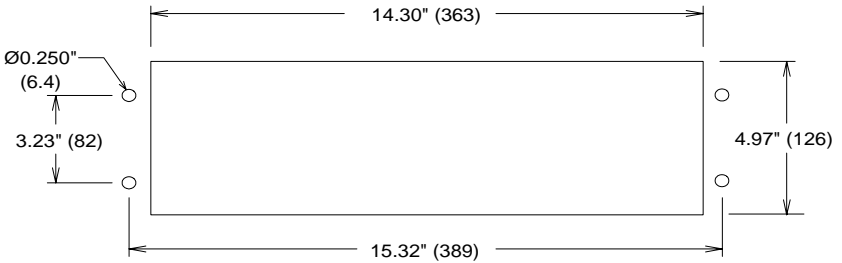

Figure 17. PD757 Panel Mounting Cutout Dimensions

Parts Supplied with Panel Mounting Kit:

1. Two angle brackets
2. One self-adhesive decorative bezel
3. Eight #12-24 x ¾" screws
4. Eight #12 lock washers
5. Eight #12-24 hex nuts
6. Four #12 flat washers

Panel Mounting Assembly Instructions:

1. Drill four holes in panel and make panel cutout as shown. Tolerance for all dimensions is ± 0.01 " (0.25 mm).
2. Secure the two side mounting brackets to the meter base using the supplied hardware.
3. Mount this assembly to the rear of the panel using supplied hardware.
4. Secure the meter cover to the base.
5. Attach decorative bezel to the panel.

Notes:

1. Allowable panel thickness: 0.06" – 0.25" (1.5 mm x 6.4 mm). Longer bracket screws may be used for panel thickness up to 0.5" (12.7 mm).
2. Mounting space required: 7" x 17.5" x 4" (178 mm x 445 mm x 102 mm) (H x W x D). Meter cover extends 0.8" (20 mm) - X from the surface of the panel, where X equals the thickness of the panel.
3. This panel mounting kit is not intended to provide waterproof protection to the panel.
4. All dimensions are in inches and millimeters (mm).

Pipe Mounting Instructions for PD755 and PD756

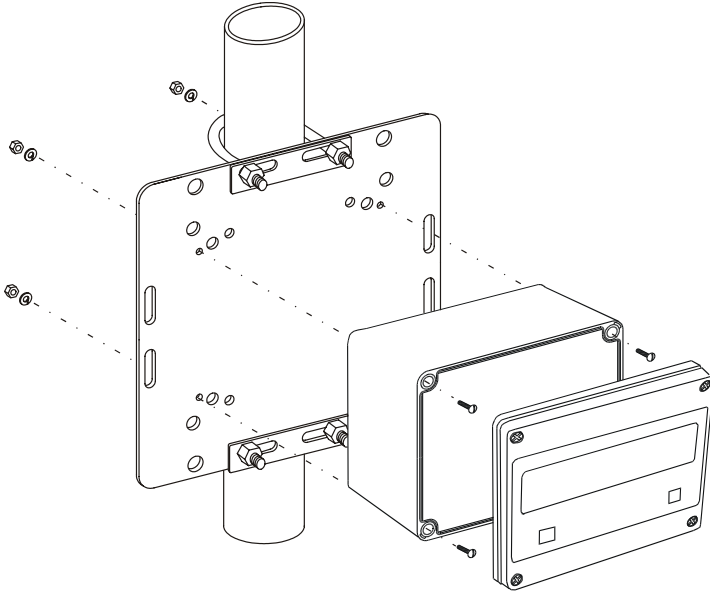

Figure 18. 755 Pipe Mounting Assembly

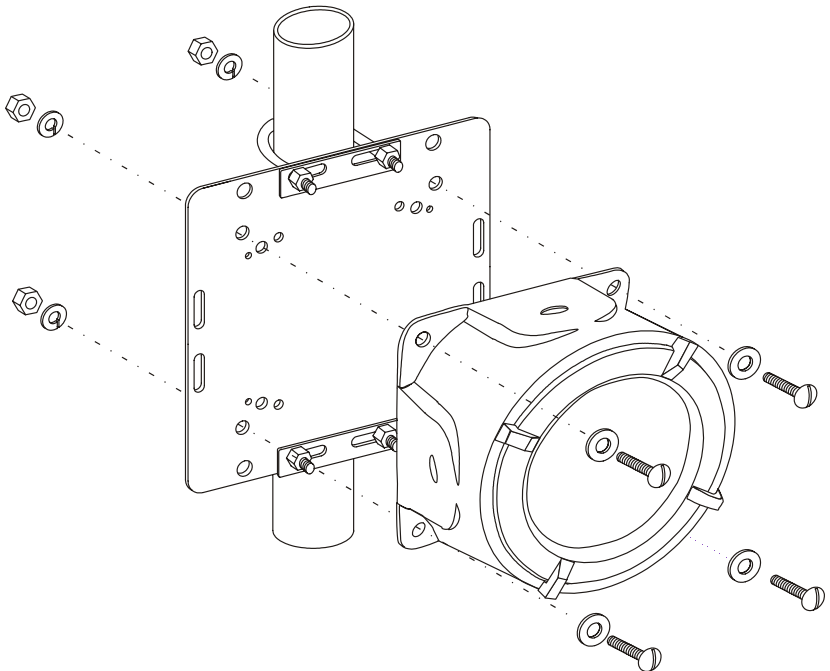

Figure 19. 756 Pipe Mounting Assembly

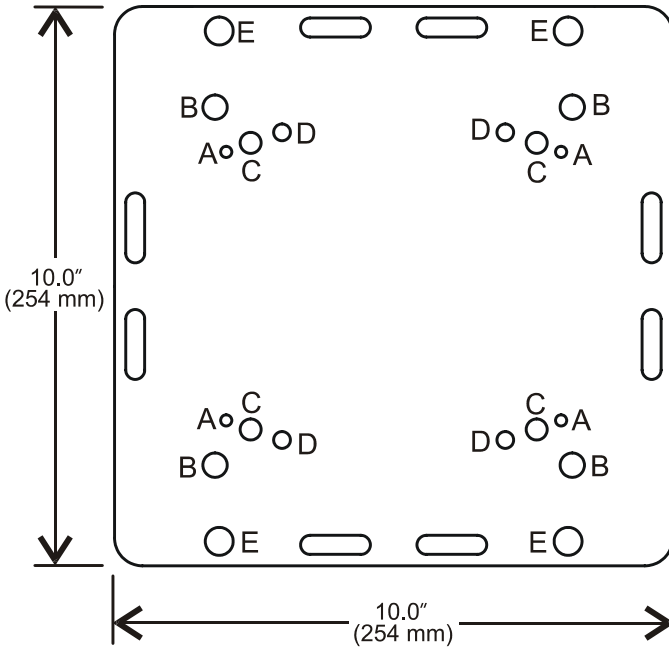

Figure 20. Pipe Mounting Plate

Parts Supplied:

1. One mounting plate
2. Two 2" U-bolt kits
3. Four 5/16–18 x 1¼ " screws
4. Four 5/16–18 hex nuts
5. Four 5/16 flat washers
6. Four 5/16 split washers
7. Four 6-32 x ¾" screws
8. Four 6-32 hex nuts
9. Four 6-32 split washers

		HARDWARE USAGE TABLE								
		(Refer to <i>Parts Supplied</i> above)								
		1.	2.	3.	4.	5.	6.	7.	8.	9.
Model	Hole									
PD755	A	X	X					X	X	X
PD756	B	X	X	X	X	X	X			

Explosion-Proof Control Stations

The explosion-proof control stations can be used to control the PD756 while in operation in a hazardous area. Control stations may be ordered with one, two, or three push buttons. The buttons can be labeled ENTER, ACK, and RESET. External connections are available at J1 connector on the main Board.

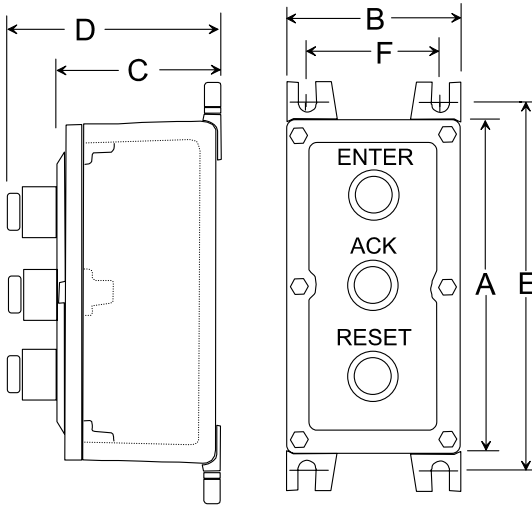

Figure 21. Explosion-proof Control Station

Number of Switches	Dimensions in Inches and mm()						Wt lbs (kg)	Std. Cond. Size
	A	B	C	D	E	F		
1	4.5 (114)	4.5 (114)	4.19 (106)	6.19 (157)	5.5 (140)	3.25 (83)	4.5 (2.0)	3/4"
2	7.0 (178)	4.5 (114)	4.19 (106)	6.19 (157)	8.0 (203)	3.25 (83)	6.0 (2.7)	3/4"
3	8.0 (203)	4.5 (114)	4.19 (106)	6.19 (157)	9.0 (229)	3.25 (83)	6.75 (3.1)	3/4"

Note: The Control Stations have conduit openings centered on top and bottom.

OPTION CARD REMOVAL & INSTALLATION

Meter options are installed at the factory. To disable relays' fail-safe operation, it is necessary to remove the Display Board to gain access to the Options Board. Option cards may be ordered separately. Refer to the following instructions and illustrations.

Option Card Installation in PD755

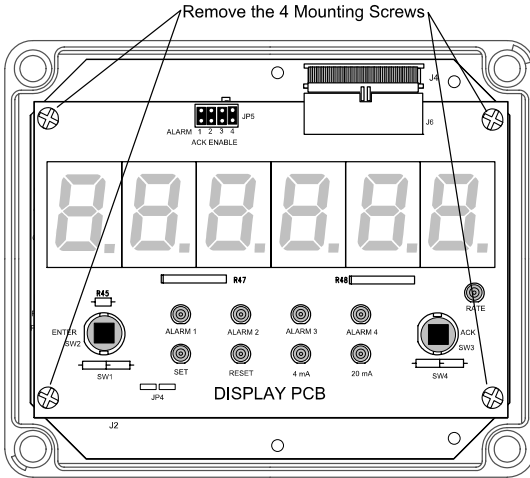

Figure 22. Removing the PD755 Display Board

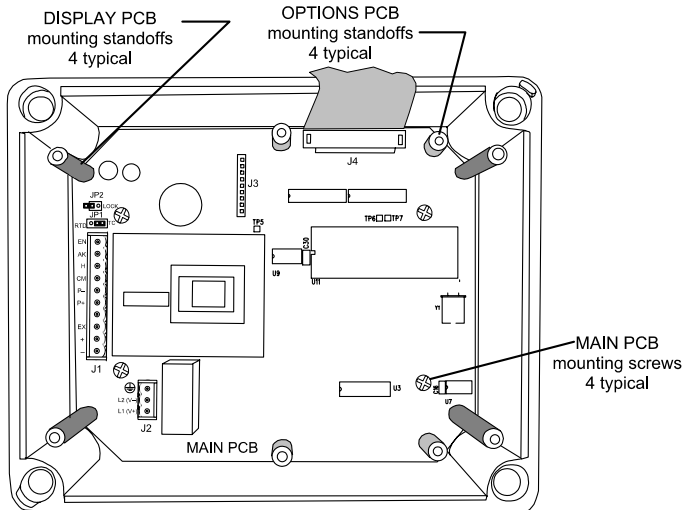

Figure 23. PD755 Options Board Standoffs Location

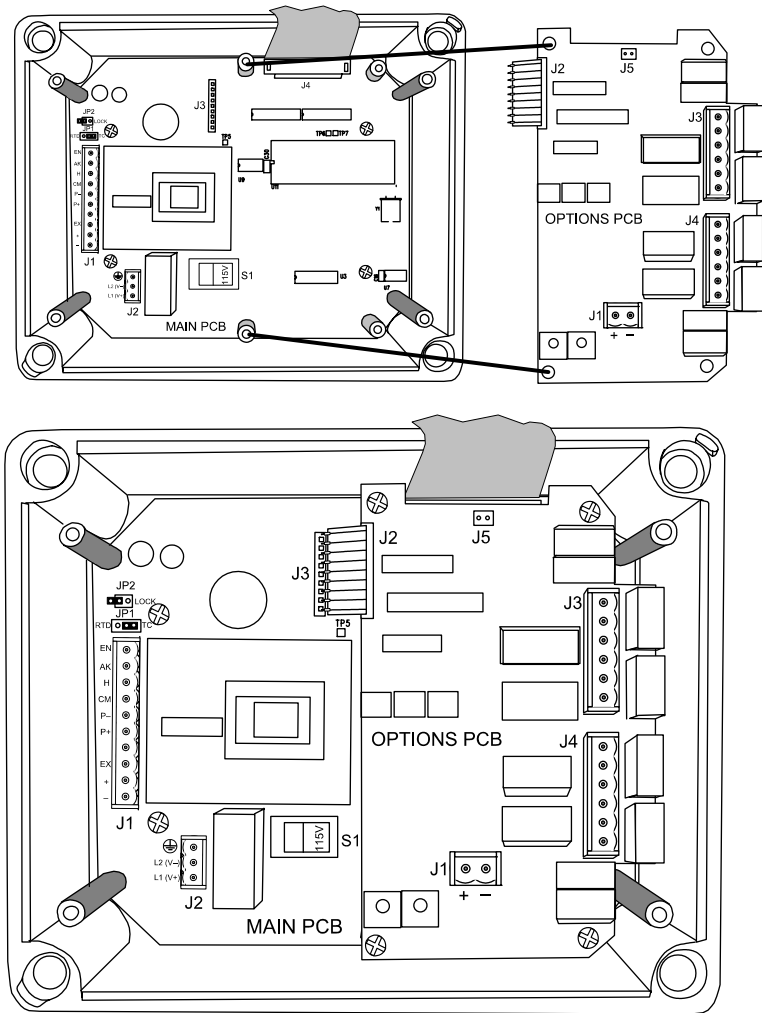

Figure 24. PD755 Options Board Installation

Instructions:

1. Disconnect power to the meter prior to removing the front cover.
2. Remove Display Board and detach Board from ribbon cable connector.
3. Remove Main Board from the base by removing four mounting screws.
4. Install Options Board standoffs, using provided hex nuts.
5. Connect flexible cable connector J2 to J3 connector on Main Board.
6. Install 4 mounting screws to secure Options Board to standoffs.
7. Reassemble meter prior to applying power. Front cover may remain off until programming is completed to allow installation of lockout jumper (see Figure 31, page 61).

Option Card Installation in PD756

To install the Options Board into PD756, refer to the following figures.

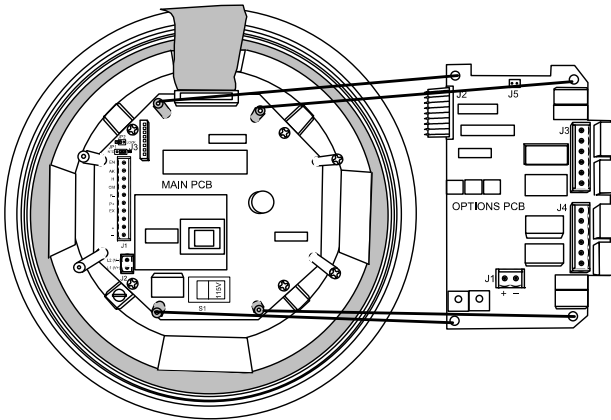

Figure 25. PD756 Option Board Installation

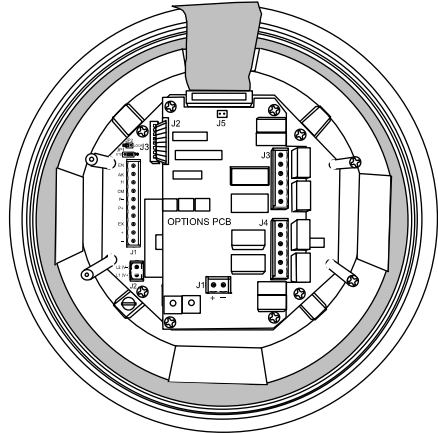

Figure 26. PD756 Option Board Installed

Instructions:

1. Disconnect power to the meter prior to removing the front cover.
2. Remove Display Board and detach Board from ribbon cable connector. Display Board may be removed without removing the faceplate.
3. Remove Main Board from the base by removing four mounting screws.
4. Install Options Board standoffs, using provided hex nuts.
5. Connect flexible cable connector J2 to J3 connector on Main Board.
6. Install 4 mounting screws to secure Options Board to standoffs.
7. Reassemble meter prior to applying power. Front cover may remain off until programming is completed to allow installation of lockout jumper (see Figure 32, page 62).

Option Card Installation in PD757

To install the Options Board into PD757, refer to the following figure.

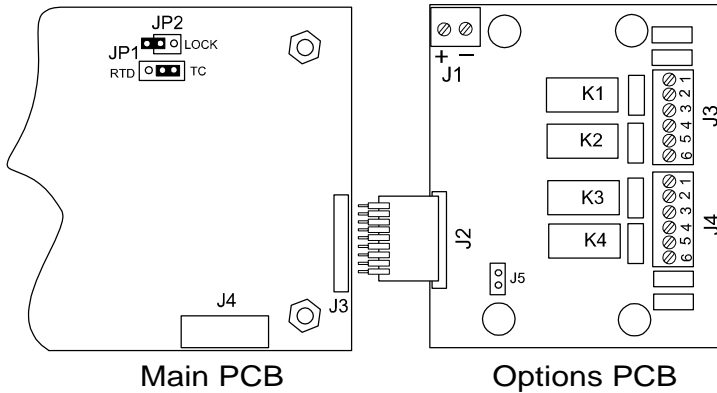

Figure 27. PD757 Option Board Installation

Instructions:

1. Disconnect power to the meter prior to removing the front cover.
2. Remove Display Board and detach Board from ribbon cable connector.
3. Remove two right-side standoffs and plastic washers; discard plastic washers.
4. Install Options Board, using the two standoffs removed in step 3.
5. Connect flexible cable connector J2 to J3 connector on Main Board.
6. Reassemble meter prior to applying power. Front cover may remain off until programming is complete to allow access to **ENTER** and **ACK** buttons as well as installation of lockout jumper (see Figure 36, page 64).

MODEL SPECIFIC ILLUSTRATIONS

Removing the Display Board

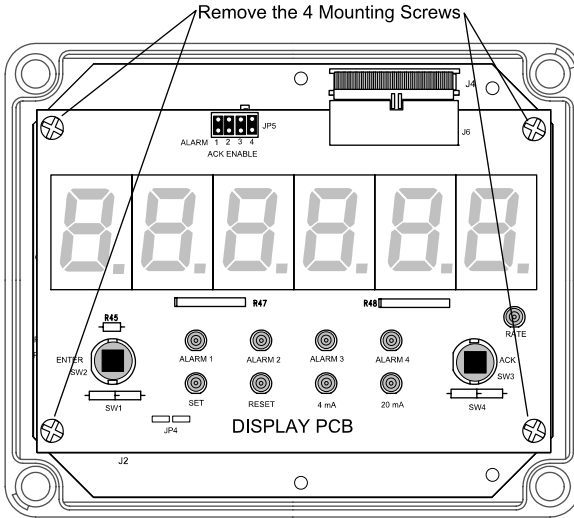

Figure 28. Removing the Display Board on PD755

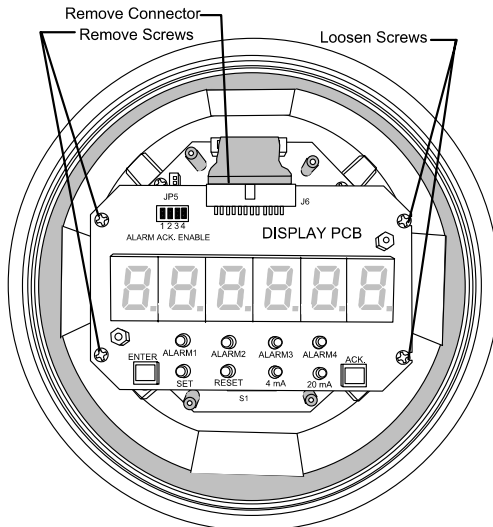

Figure 29. Removing the Display Board on PD756

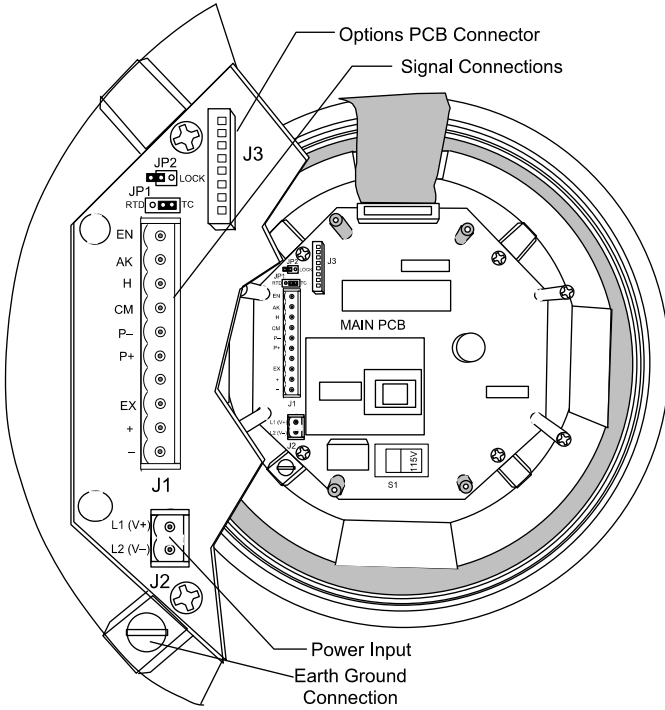

Figure 32. PD756 Connectors and Jumper Location

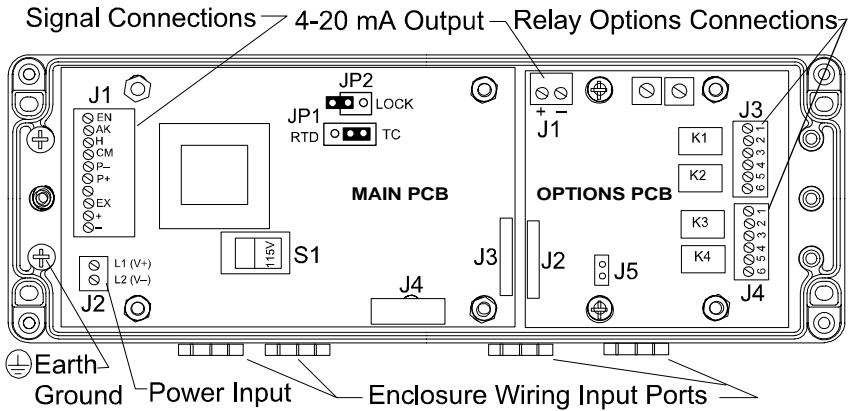

Figure 33. PD757 Connectors and Jumper Location

Jumper Arrays and Status LEDs

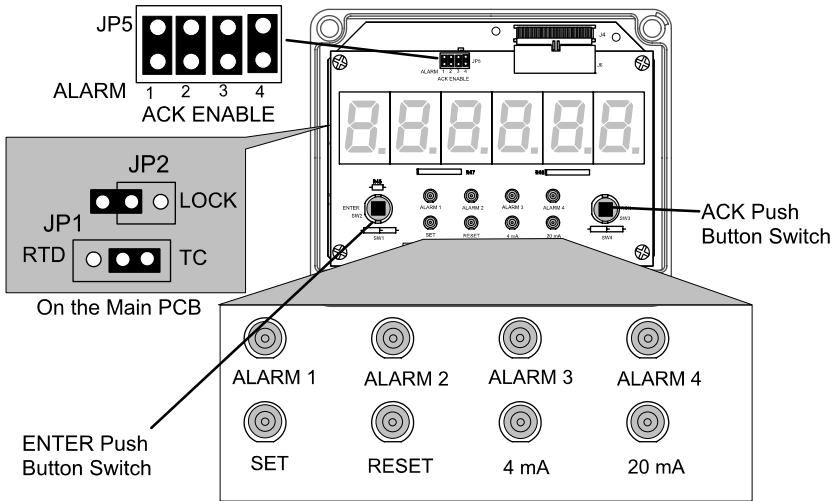

Figure 34. PD755 Jumper Arrays and Status LED Identification

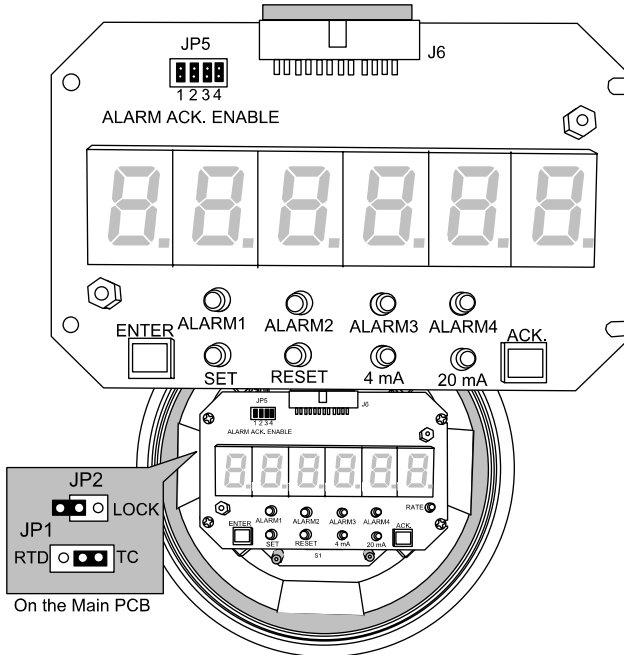

Figure 35. PD756 Jumper Arrays and Status LED Identification

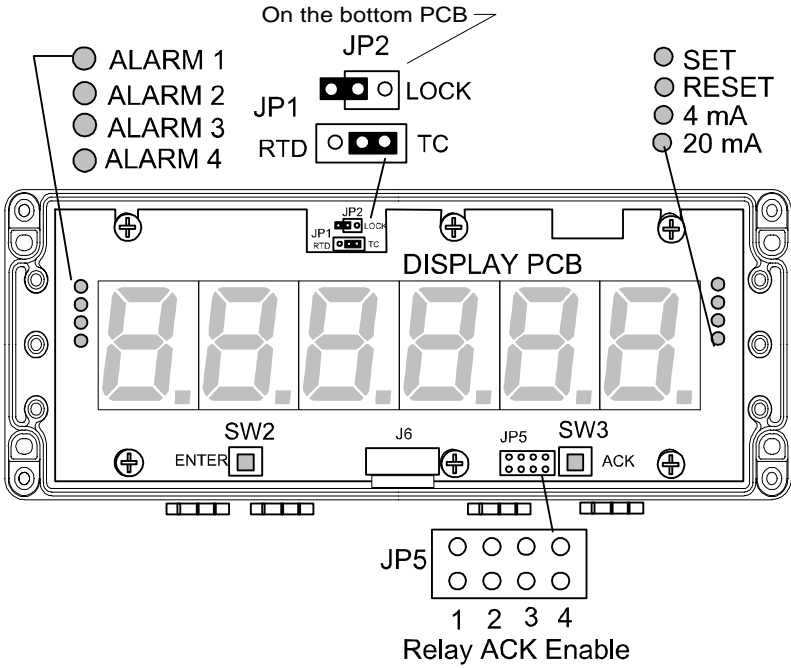

Figure 36. PD757 Jumper Arrays and Status LED Identification

Front Panel Displays

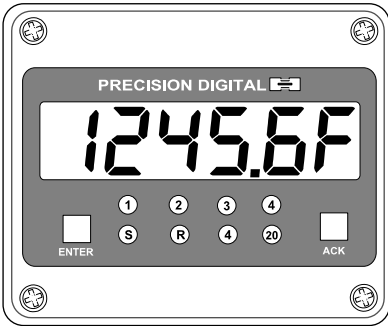

Figure 37. PD755 Front Panel Display



Figure 38. PD756 Front Panel Display

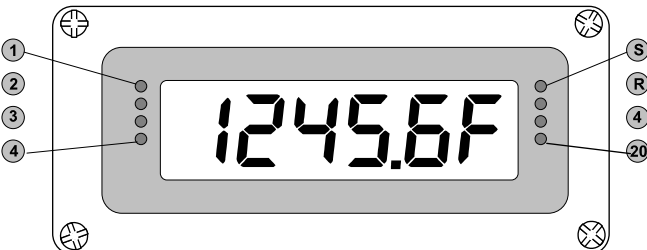

Figure 39. PD757 Front Panel Display

Overall Dimensions

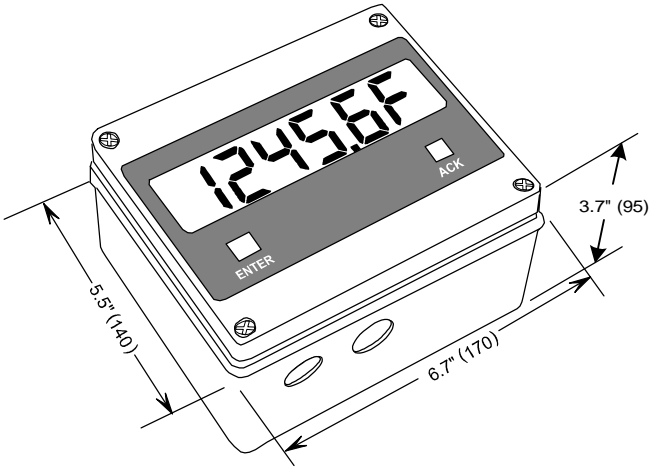

Figure 40. PD755 Overall Dimensions

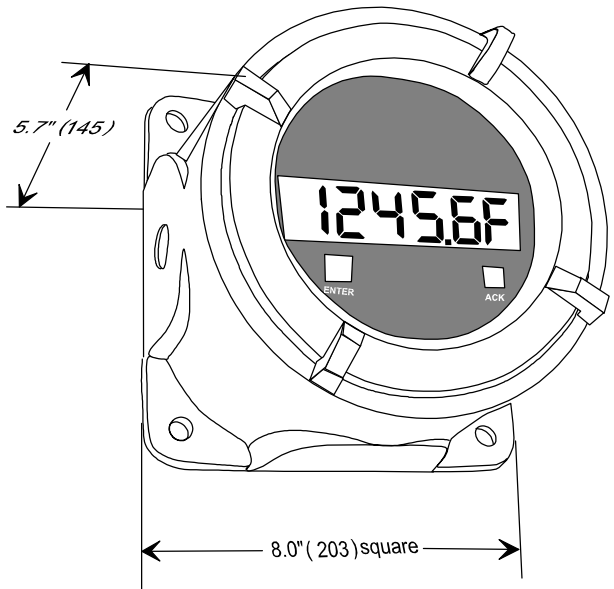

Figure 41. PD756 Overall Dimensions

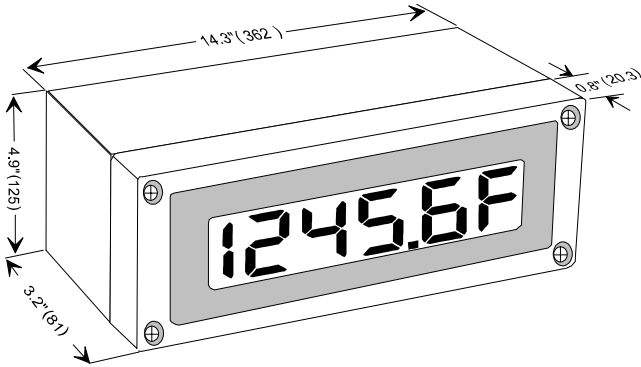

Figure 42. PD757 Overall Dimensions

Wall Mounting Dimensions

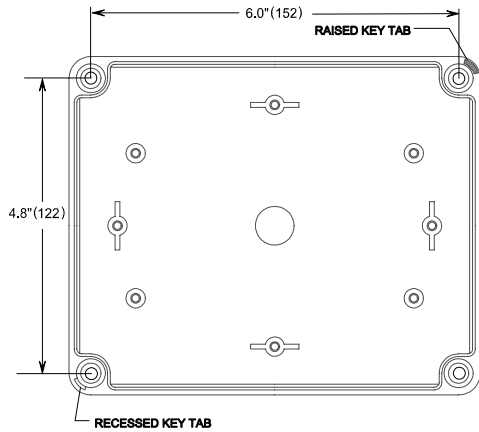

Figure 43. PD755 Wall Mounting Dimensions

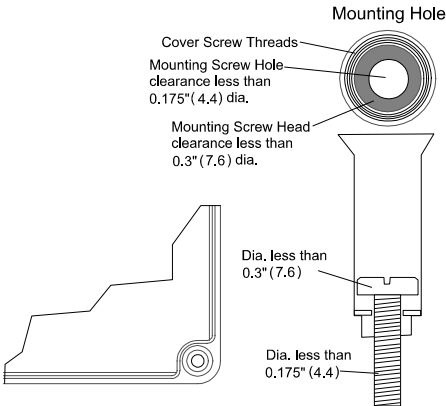

Figure 44. PD755 Wall Mounting Screw Installation

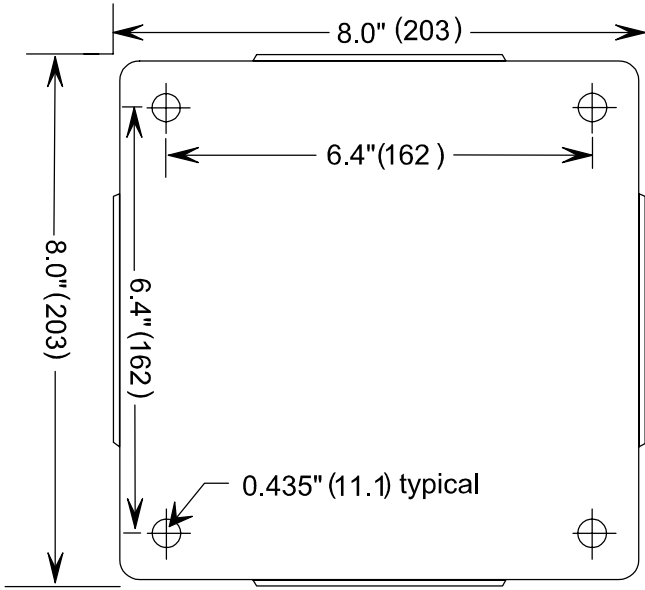

Figure 45. PD756 Wall Mounting Dimensions

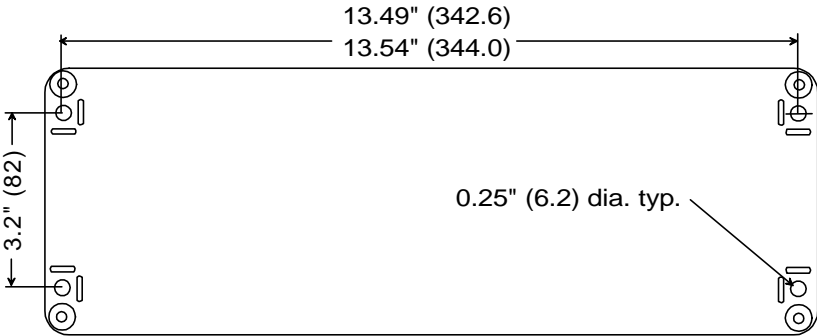

Figure 46. PD757 Wall Mounting Dimensions

PROGRAMMED PARAMETER SETTINGS

The following table shows the factory setting for most of the programmable parameters on the Digital Temperature Meter. Next to the factory setting, the user may record the new setting for the particular application.

Model: _____ S/N: _____ Date: _____

Parameter	Display	Factory Setting	User Setting
Input type	TYPE	J T/C (TYPE 0)	
Input Offset	OFFSET	00000F	
Temperature Scale	F or C	Fahrenheit (F)	
Alarm Points Setup	SETUP	Non-latching (Automatic reset)	
	SET 1	LATCH	n (No)
	SET 2	LATCH	n (No)
	SET 3	LATCH	n (No)
	SET 4	LATCH	n (No)
Alarms set points	SETPTS		
Alarm 1	SET 1	Set	00 100F
		Reset	00050F
Alarm 2	SET 2	Set	00200F
		Reset	00 150F
Alarm 3	SET 3	Set	00300F
		Reset	00250F
Alarm 4	SET 4	Set	00400F
		Reset	00350F
Output	outPut		
		4 mA	000.00F
		20 mA	100.00F

OTHER PRECISION DIGITAL PRODUCTS

Model	Description
PD118	MINIMUX [®] 8 Point Scanner
PD141AFO	VIGILANTE [®] four Point Annunciator with First-Out
PD202	General Purpose Digital Pressure Gauge
PD213-224	Industrial Digital Pressure Gauges (FM & CSA)
PD233-253	Precision Digital Test Pressure Gauges (FM & CSA)
PD602	Dart Low-Cost 1/8 DIN Process Meter
PD644	Javelin D High-Voltage DC Panel Meter (UL Listed)
PD650	2.3" LED NEMA 4X Large Display Process Meter
PD655	1.0" LED NEMA 4X Large Display Process Meter
PD656	0.8" LED Exp-Proof Large Display Process Meter
PD660	Low-Cost NEMA 4X Loop Powered Meter
PD661	Low-Cost Exp-Proof Loop Powered Meter (FM & CSA)
PD673	4½ Digit Loop Powered 1/8 DIN Meter
PD675	4½ Digit Loop Powered NEMA 4X Meter (FM & CSA)
PD677	4½ Digit Loop Powered Exp-Proof Meter
PD685	3½ Digit Loop Powered NEMA 4X Meter (General Purpose)
PD686	3½ Digit Loop Powered NEMA 4X Meter (FM & CSA)
PD687	3½ Digit Loop Powered Exp-Proof Meter (FM & CSA)
PD690	1/8 DIN Analog Input Process Meter (UL Listed)
PD691	1/8 DIN Strain Gauge & mV Input Meter (UL Listed)
PD692	1/8 DIN Analog Input Flow Rate/Totalizer (UL Listed)
PD693	1/8 DIN Freq/Pulse Input Flow Totalizer (UL Listed)
PD696	1/8 DIN Loop Powered Flow Rate/Totalizer
PD697	NEMA 4X Loop Powered Flow Rate/Totalizer
PD698	Exp-Proof Loop Powered Flow Rate/Totalizer (FM & CSA)
PD740	Javelin T Low-Cost TC & RTD Temperature Meter (UL Listed)
PD750	TC & RTD Temperature Meter (UL Listed)
PD751	10 Ω Cu RTD Temperature Meters (UL Listed)
PD752	120 Ω Ni RTD Temperature Meters (UL Listed)
PD765	Trident Process & Temperature Meter (UL Listed)
PD865	Snooper Modbus Serial Input Meter (UL Listed)
PD940 & 941	ConsoliDator [®] 4 Multi-Channel Controllers (UL Listed)
PD980 & 981	ConsoliDator [®] 8 Multi-Channel Controllers (UL Listed)

How to Contact Precision Digital

- For Technical Support please
call: (800) 610-5239 or (508) 655-7300
fax: (508) 655-8990
e-mail: support@predig.com
- For Sales Support or to place an order please
call: (800) 343-1001 or (508) 655-7300
fax: (508) 655-8990
e-mail: sales@predig.com
- For Extended Warranty, Setup & Calibration Services please visit
www.predig.com
- For an online version of this instruction manual please visit
www.predig.com

